

2U12-BAY SERIES SERVER CHASSIS

Product Manual V1.0

CONTENTS

Chapter 1: Product Introduction	02
1.1 Product features	02
1.2 Chassis Structure	03
1.3 Description of Front Panel and Hard Drive Bay	04
1.3.1 Front Panel and Indicator Lights	04
1.3.2 Hard Drive Installation and Hard Drive Tray Indicator Light Instructions	05
1.4 Hard Drive Backplane	06
1.4.1 12-Bay Backplane: 12GB/SAS*8 + Nvme*4	06
1.4.2 12-Bay Backplane: 12Gb/s Expander	07
Chapter 2: Product Appearance	08
2.1 Chassis Structure	08
2.1.1 Chassis Diagram	08
2.1.2 Server Chassis Images	10
2.1.3 Server Dimensions	11
Chapter 3: Product Loading and Unloading	12
3.1 Removal of the Rear Top Cover	12
3.1.1 Disassembly Steps	12
3.2 Installation of the Power Supply	13
3.2.1 Installation Steps	13
Chapter 4: Product Loading	15
4.1 Product Packaging	15
Chapter 5: Product and Rail Installation	16
5.1 Install inner rails on both sides of the chassis	16
5.2 The chassis is mounted into the rack	16
Chapter 6: Accessory Name and Part Number	17
6.1 Accessories and Material Numbers	16
6.2 Optional Accessories List	17

Chapter 1: Product Introduction

1.1 Product Features

Product Code	K32012	K32027	K32018	K32019	K32020
Chassis Category	2U Rack mount				
Material	SGCC1.2mm(Taiwan)				
MB Form Factor	Extended ATX (12"x 13")				
Dimensions (D*W*H)	660 * 435 * 88.1(mm) 25.98"x 17.12"x 3.47 "				
Drive Bays	3.5"Hot-swap: 12 , Internal 2.5": 2 , 2.5"Hot-swap (Option): 2				
PSU Form Factor	2U Single or 1+1 Redundant				
Indicators	1 * Power Status , 2 * LAN Activity, 1 * UID Status , 1 * HDD Status , 1 * Warning Status				
Front Control	1 * Power On/Off , 1 * System Reset, 1 * UID 2 * USB 2.0 , USB3.0 + VGA(Option)				
Safety Device	Intrusion Switch (Option)				
Cooling Fans	Middle : 3 x 80 mm (T=38mm) PWM , 7500RPM		Middle : 2 x 80mm (T=38mm) , PWM , 15000RPM Middle : 1 x 80mm (T=38mm) , PWM , 7500RPM		
Expansion Slots	Length or 7 x Low Profile	Length or 9 x Low Profile	Supports 2nd PCIE, 3X Full Height	Supports 3rd PCIE, 3X Full Height	Supports 4nd PCIE, 3X Full Height
Riser card module	NO		Option		
HDD Backplane	12-port 12Gb/s - SAS backplane, 12-port 12Gb/s Expander - SAS(option) Three models backplane(option)				
Rack rails	P/N:0304100006(Option)				
Net Weight	11kg				
Gross Weight	13.4kg				
Package size(D*W*H)	730x620x220mm				

1.2 Chassis Structure

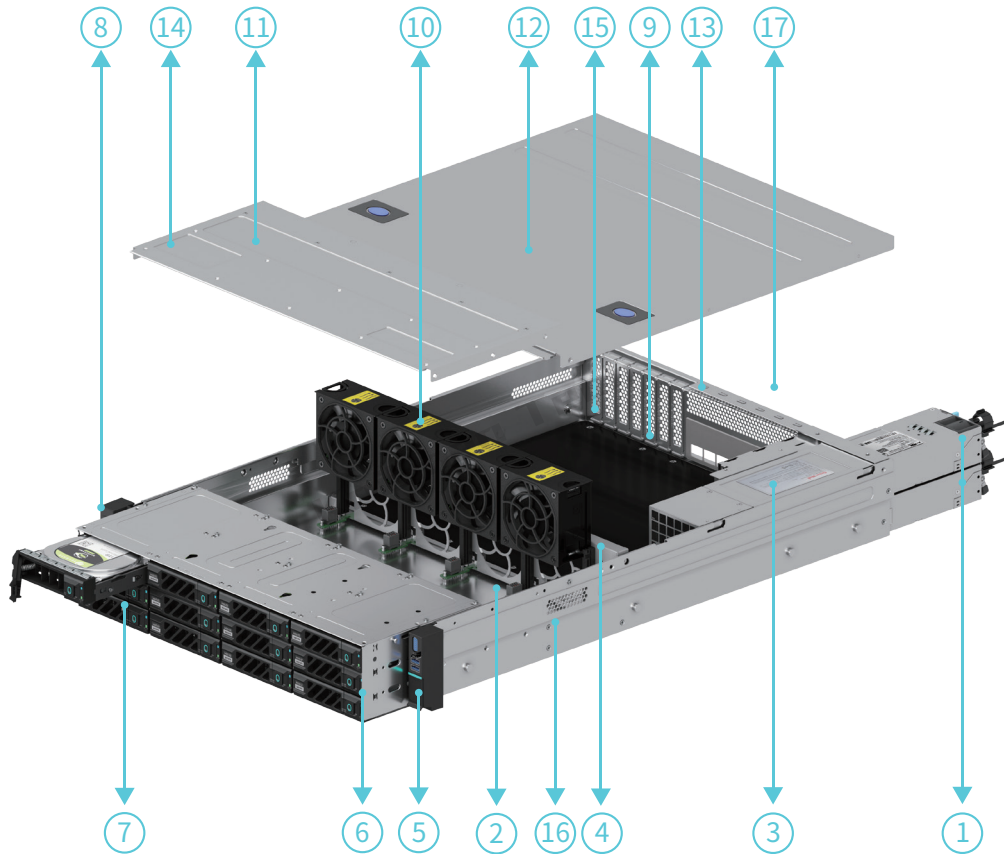

- | | |
|--|--|
| 1. Power Supply | 10. Fan Module |
| 2. Hard Drive Backplane | 11. Front Cover |
| 3. Power Supply Bracket | 12. Rear Cover |
| 4. Fan Wall | 13. Rear Window Assembly |
| 5. Right Bracket Assembly | 14. Chassis Layout Diagram Sticker |
| 6. 2U 12 Hard Drive Cage Assembly | 15. Standard 7 PCIe Expansion Slots |
| 7. 3.5-inch Hard Drive Tray | 16. Chassis Base |
| 8. Left Bracket Assembly | 17. 2.5-inch Hard Drive Enclosure Module |
| 9. Internal 2.5-inch Hard Drive Mounting Bracket | |

1.3 Description of Front Panel and Hard Drive Bay

1.3.1 Front Panel and Indicator Lights:



HD00	HD01	HD02	HD03
HD04	HD05	HD06	HD07
HD08	HD09	HD10	HD11

- | | | |
|-------------------------------------|---|---------------------------------|
| 1. Server Information Label | 2. Expand VGA Port | 3. USB 3.0 x 2 |
| 4. USB 2.0 x 2 | 5. Power Button + Power Indicator Light | 6. UID Button + Indicator Light |
| 7. Reset Button | 8. HDD Indicator Light | 9. Fault Indicator Light |
| 10. Ethernet Port 1 Indicator Light | 11. Ethernet Port 2 Indicator Light | |

Control Panel Buttons and Interface Description:

Power Button	Power button, press once to power on when the system is powered; In the powered-on state, press and hold for 5 seconds to shut down the system.
Reset Button	In the powered-on state, press once to restart the device.
UID Button	In the powered-on state, press once to illuminate the indicator light.

Control Panel Indicator Light Explanation:

Name	Color	Status	Description
Power Light	Blue	On	The server is in the powered-on state.
UID Light	Blue	On	The server is in the located state.
Fault Indicator Light	Red	On	The server is experiencing a malfunction.
Network 1 Indicator Light	Green	On	The network connection is normal.
Network 2 Indicator Light	Green	On	The network connection is normal.
HDD Indicator Light	Yellow	On	The hard drive is in operational status.

1.3.2 Hard Drive Installation and Hard Drive Tray Indicator Light Instructions:

3.5-inch Hard Drive Installation Guide:

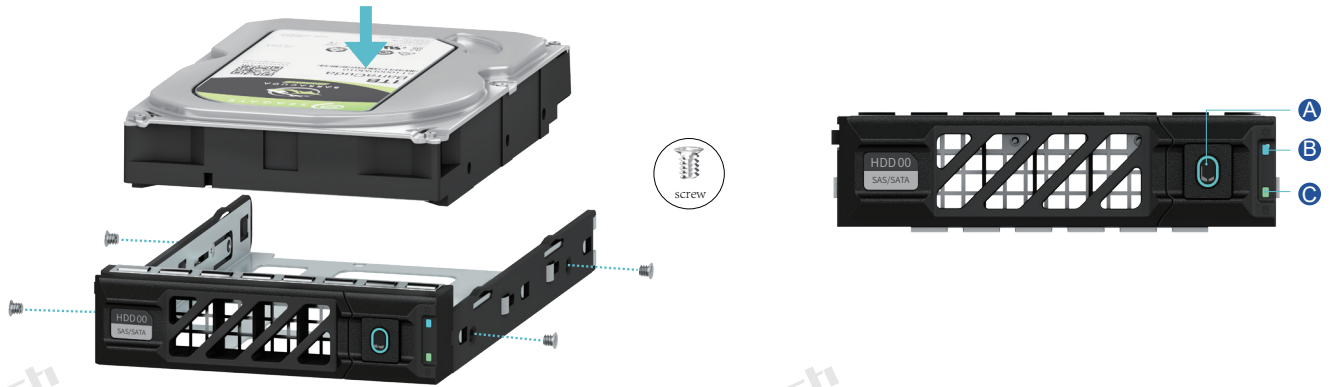

- A. Power On Button
- B. Power Indicator Light
- C. Status Indicator Light

2.5-inch Hard Drive Installation Guide:

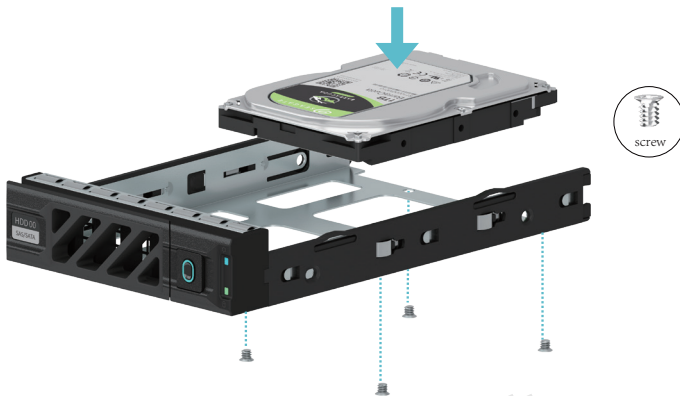

Hard Drive Tray Indicator Light Instructions	
B	Blue: Hard Drive Powered On Solid Green: Hard Drive in Position
C	Flashing Green: Hard Drive Activity Solid/Flashing Red: Hard Drive Failure

2.5-inch Hard Drive Installation Guide:

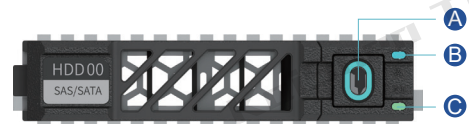

- A. Power On Button
- B. Power Indicator Light
- C. Status Indicator Light

Hard Drive Tray Indicator Light Instructions	
B	Blue: Hard Drive Powered On Solid Green: Hard Drive in Position
C	Flashing Green: Hard Drive Activity Solid/Flashing Red: Hard Drive Failure

1.4 Hard Drive Backplane

1.4.1 12-Bay Backplane: 12GB/SAS*8 + Nvme*4

TOP Plane:

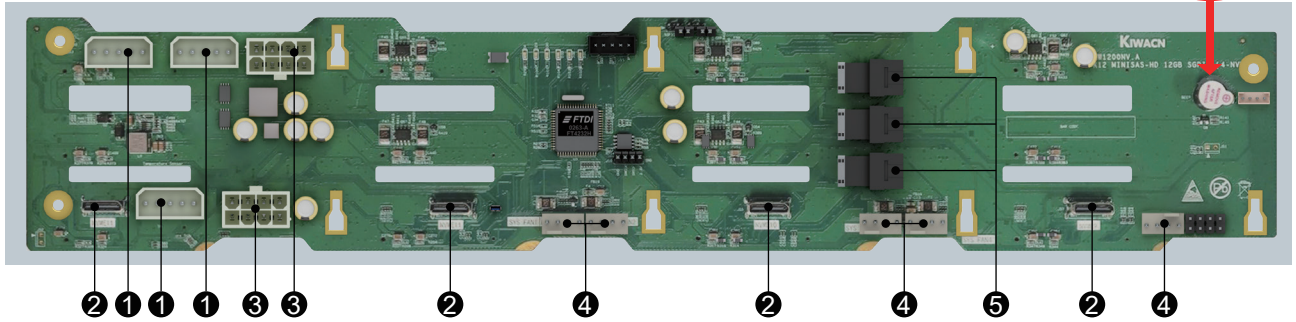

Label	Device Description	Function Description	Location Identifier
1	ATX 4P Power Connector	Backplane Power Transmission Connector, used for 12V power supply transmission. <i>(Pay attention to the orientation of the interface!!! And do not connect it simultaneously with the large 8-pin connector (③)!!!)</i>	J2, J4, J6
2	Nvme 8611Connector	Nvme 3.0 Connector(Optional)	NVME9, NVME10, NVME11, NVME12
3	8P Power Connector	Backplane Power Transmission Connector, used for 12V power supply transmission <i>Note: Cannot be connected simultaneously with the large 8-pin connector (①)</i>	J5, J60
4	Fan Power Connector	For use with 4-pin fan connector	SYS FAN1, SYS FAN2, SYS FAN3, SYS FAN4
5	8SFF8643 Connector	Backplane Drive Slot Signal Interface	SASHD1, SASHD2, SASHD3

BOTTOM Plane:

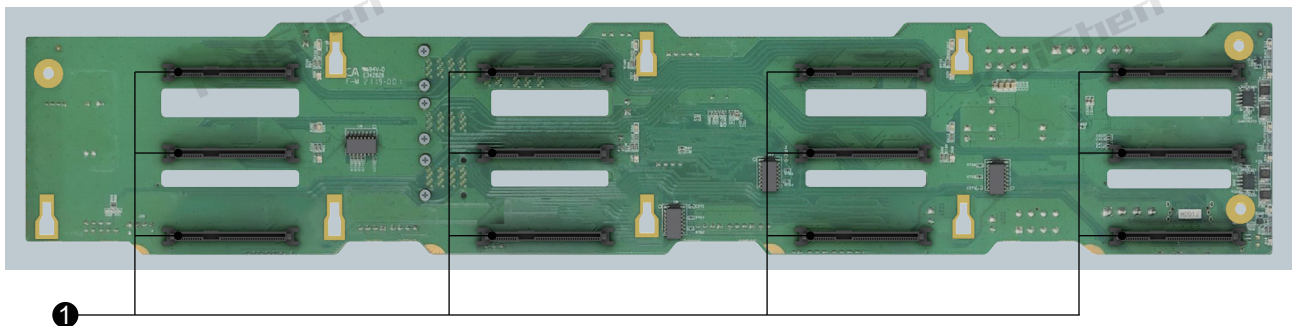

Label	Device Description	Function Description	Function Description
1	SAS/SATA Hard Drive Connector	1.Supports up to 12G/b SAS Hard Drives; 2.Supports up to 6G/b SATA Hard Drives; 3.Supports Hot-Swappable SAS/SATA Hard Drives.	HDD1, HDD2, HDD3, HDD4, HDD5, HDD6, HDD7, HDD8, HDD9, HDD10, HDD11, HDD12

1.4.2 12-Bay Backplane: 12Gb/s Expander

TOP Plane:

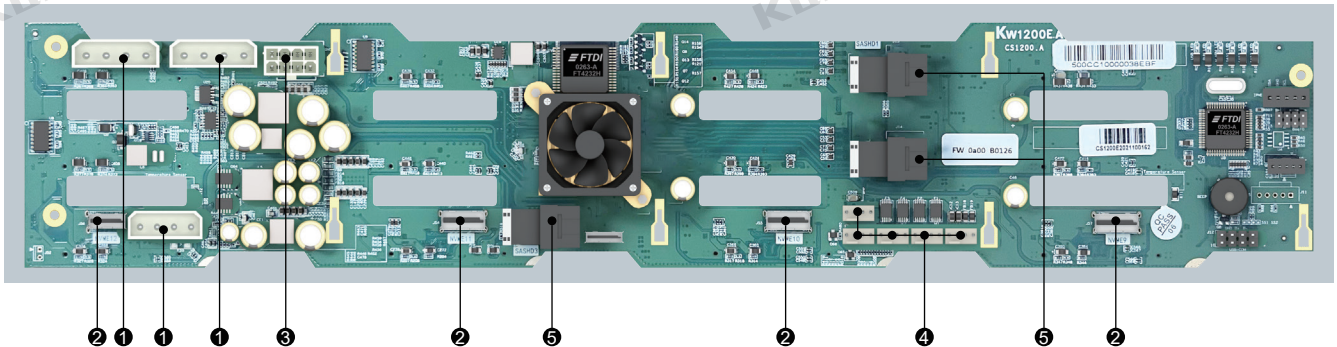

Label	Device Description	Function Description	Location Identifier
1	ATX 4P Power Connector	Backplane Power Transmission Connector, used for 12V power supply transmission. <i>(Pay attention to the orientation of the interface!!! And do not connect it simultaneously with the large 8-pin connector (③)!!!)</i>	J2, J4, J6
2	Nvme 8611Connector	Nvme 3.0 Connector(Optional)	NVME9, NVME10, NVME11, NVME12
3	8P Power Connector	Backplane Power Transmission Connector, used for 12V power supply transmission <i>(Note: Cannot be connected simultaneously with the large 8-pin connector (①)!!!)</i>	J5
4	Fan Power Connector	For use with 4-pin fan connector	J44, SYS FAN1, SYS FAN2, SYS FAN3, SYS FAN4
5	8SFF8643 Connector	Backplane Drive Slot Signal Interface	SASHD1, SASHD2, SASHD3

BOTTOM Plane:

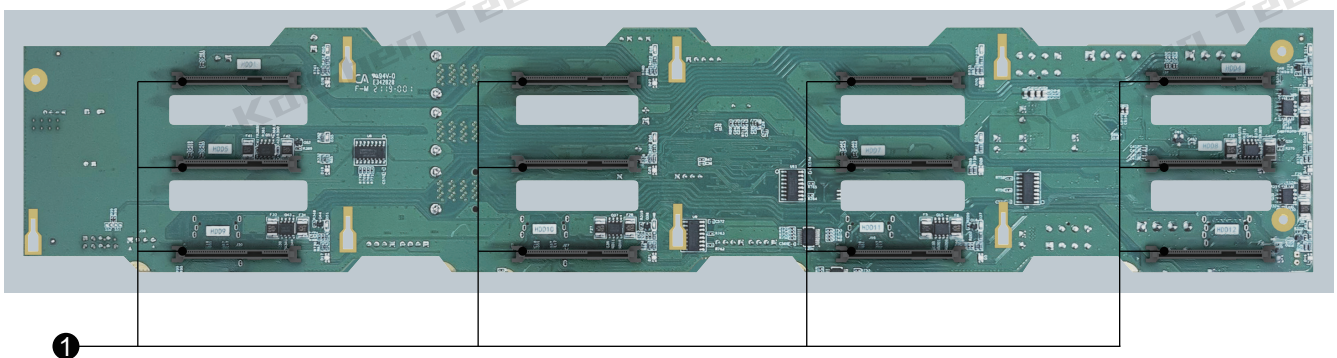

Label	Device Description	Function Description	Function Description
1	SAS/SATA Hard Drive Connector	1.Supports up to 12G/b SAS Hard Drives; 2.Supports up to 6G/b SATA Hard Drives; 3.Supports Hot-Swappable SAS/SATA Hard Drives.	HDD1, HDD2, HDD3, HDD4, HDD5, HDD6, HDD7, HDD8, HDD9, HDD10, HDD11, HDD12

Chapter 2: Product Appearance

2.1 Chassis Structure

2.1.1 Chassis Diagram

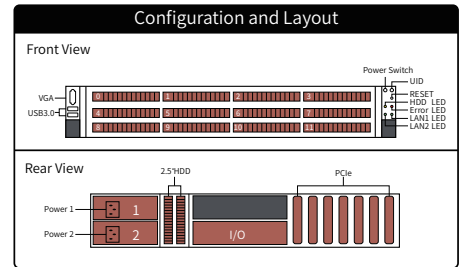

⑭ Chassis Layout Diagram Sticker ⑮ Standard 7 PCIe Expansion Slots

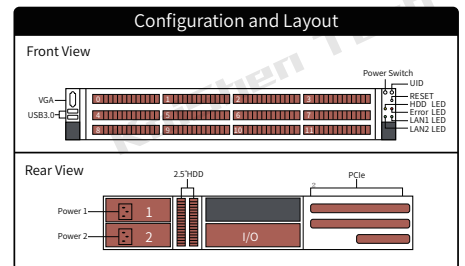
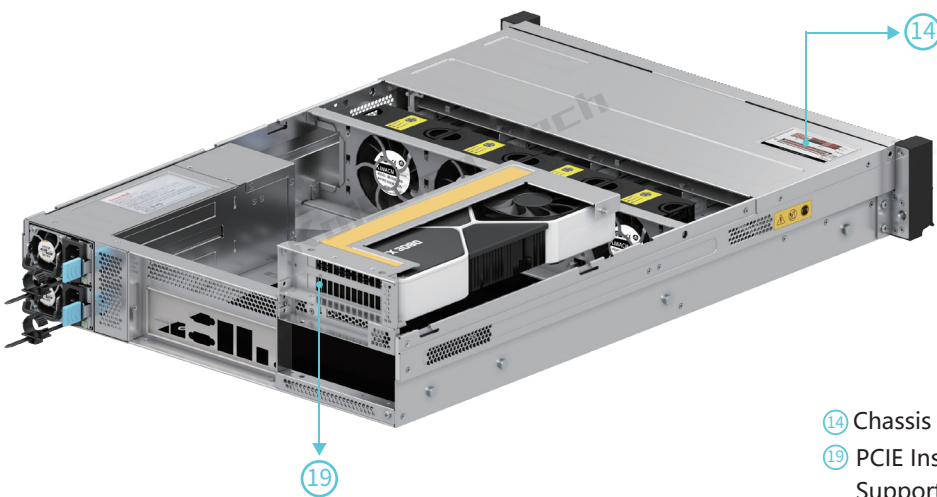

⑭ Chassis Layout Diagram Sticker
 ⑲ PCIe Installation Module (Motherboard Slot 2 Horizontal Rotation)
 Supports 16x Full-Height PCIe and 8x Half-Height PCIe



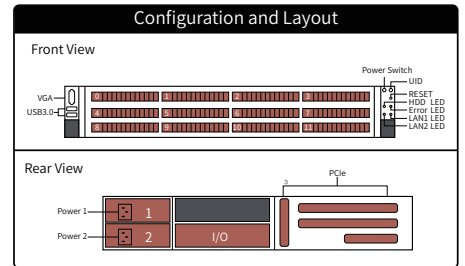
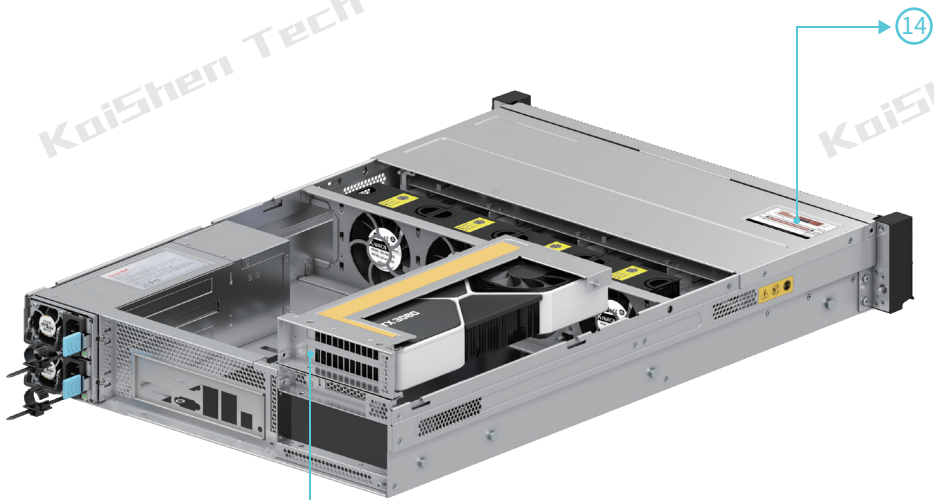

- ⑭ Chassis Layout Diagram Sticker
- ⑳ PCIe Installation Module (Motherboard Slot 3 Horizontal Rotation)
Supports 16x Full-Height PCIe and 8x Half-Height PCIe

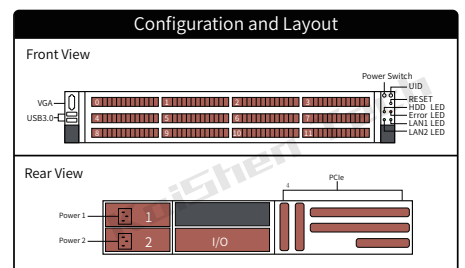
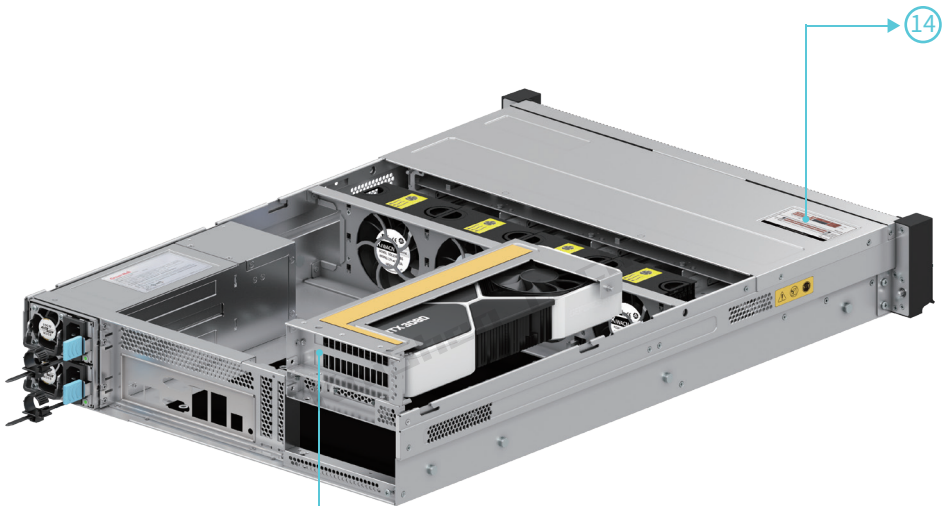

- ⑭ Chassis Layout Diagram Sticker
- ⑳ PCIe Installation Module (Motherboard Slot 4 Horizontal Rotation)
Supports 16x Full-Height PCIe and 8x Half-Height PCIe



2.1.2 Server Chassis Images



Front View



45° Side View



45° Rear View

2.1.3 Server Dimensions

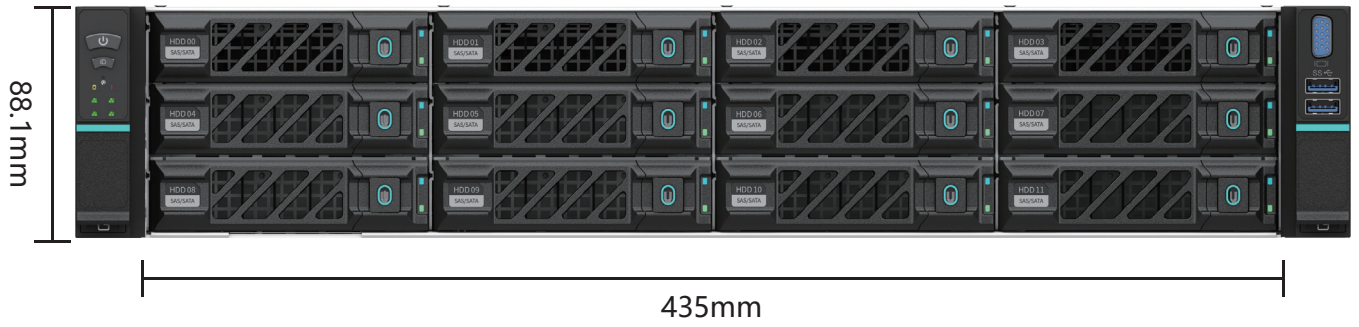

Front View (Dimensions)

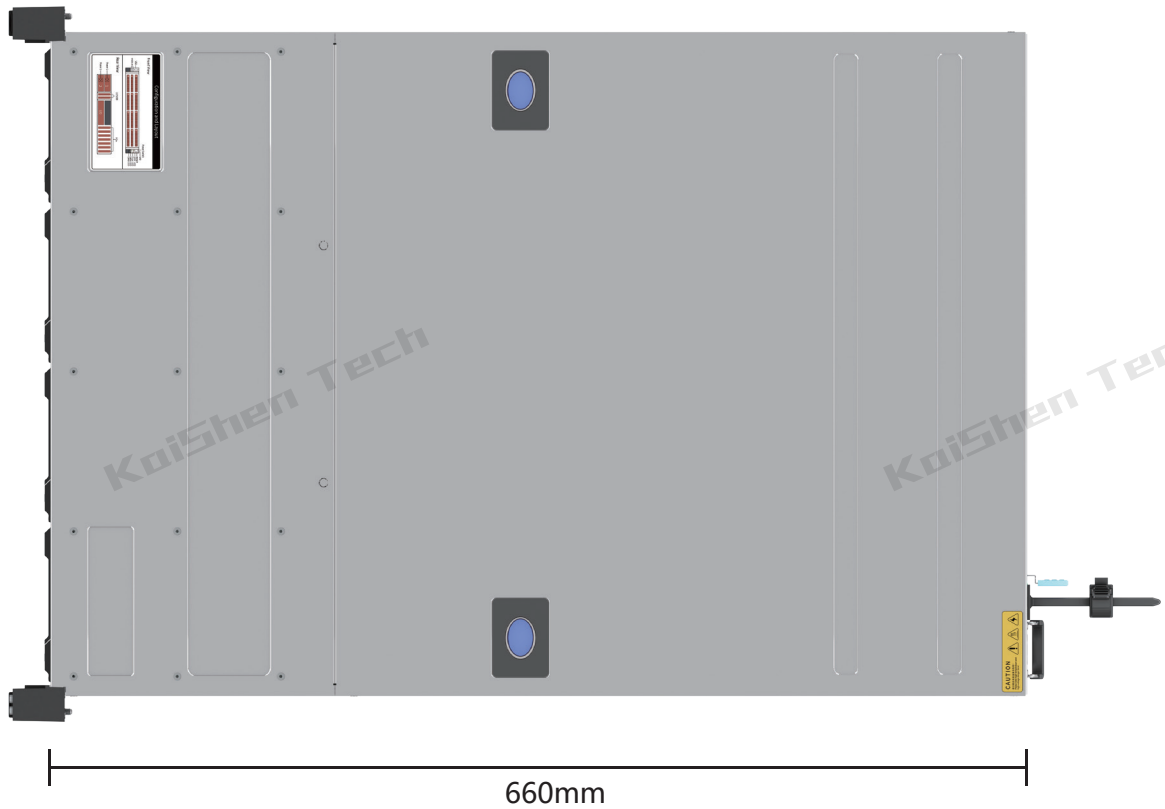

Top View (Dimensions)

Chapter 3 Product Loading and Unloading

3.1 Installation of Optical Drive

3.1.1 Steps of Installing the Optical Drive:

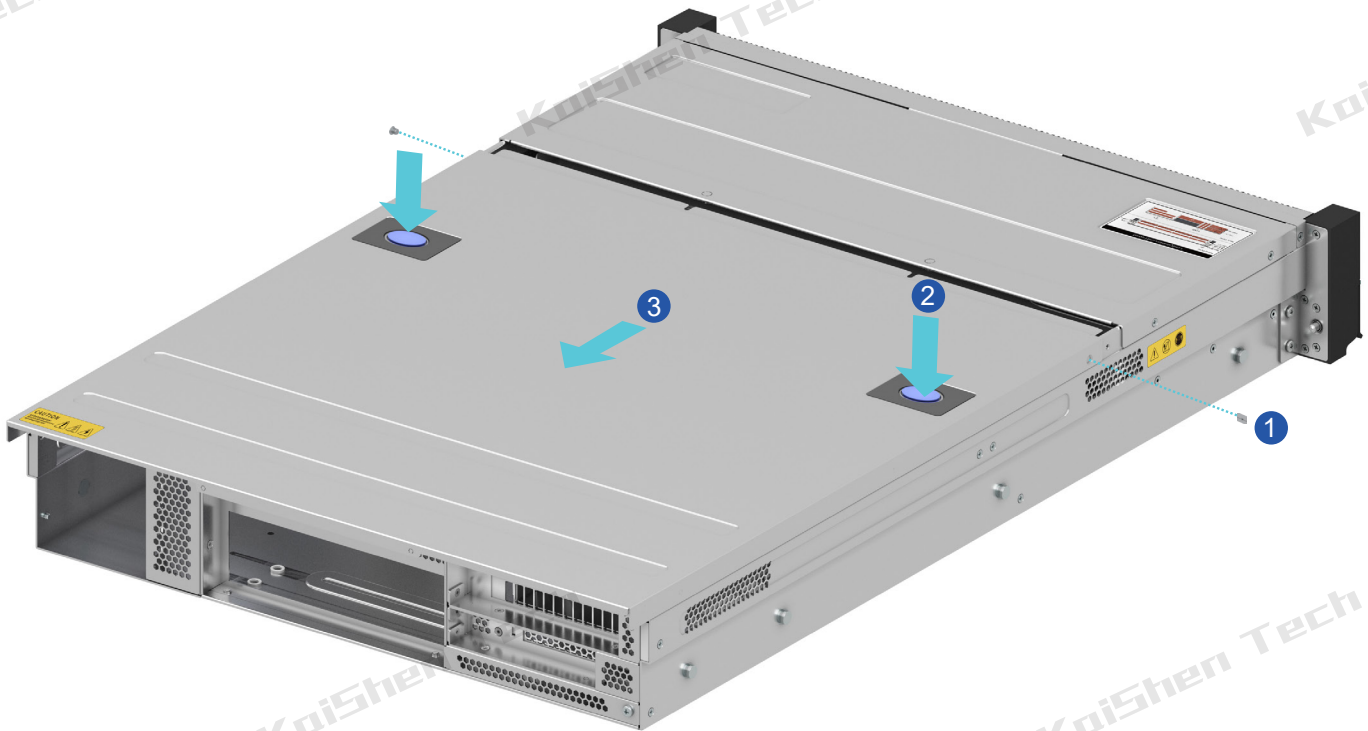

1. Loosen the screws at both ends of the upper cover as shown in the diagram, using your hands;
2. Slide the top cover towards the back in the direction of the arrow;
3. Lift off the top cover in the direction indicated by the arrow.



3.2 Installation of the Power Supply

3.2.1 Installation Steps :

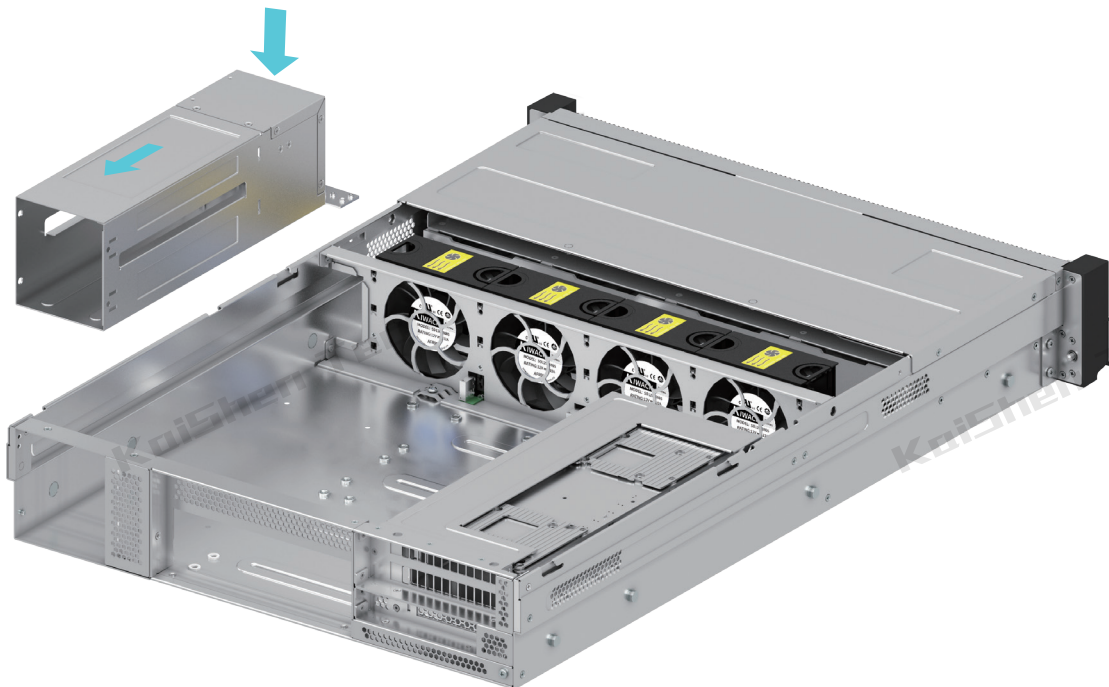

Place the power supply unit downward onto the bottom of the chassis, then push it towards the rear end. Secure it with three screws at the rear, and two screws from the bottom.

Note: Different power supply units may have slight variations in screw locations and quantity.

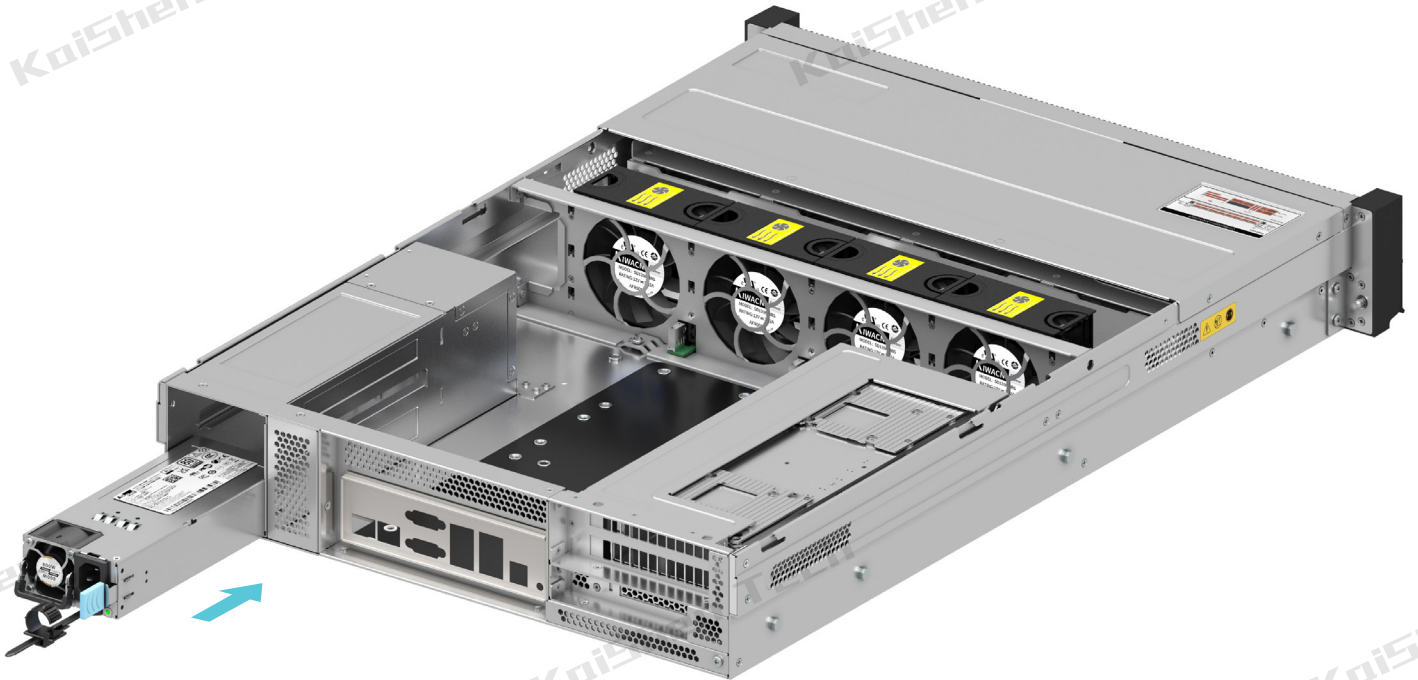

Insert power supply modules 1 and 2 into the power supply frame respectively

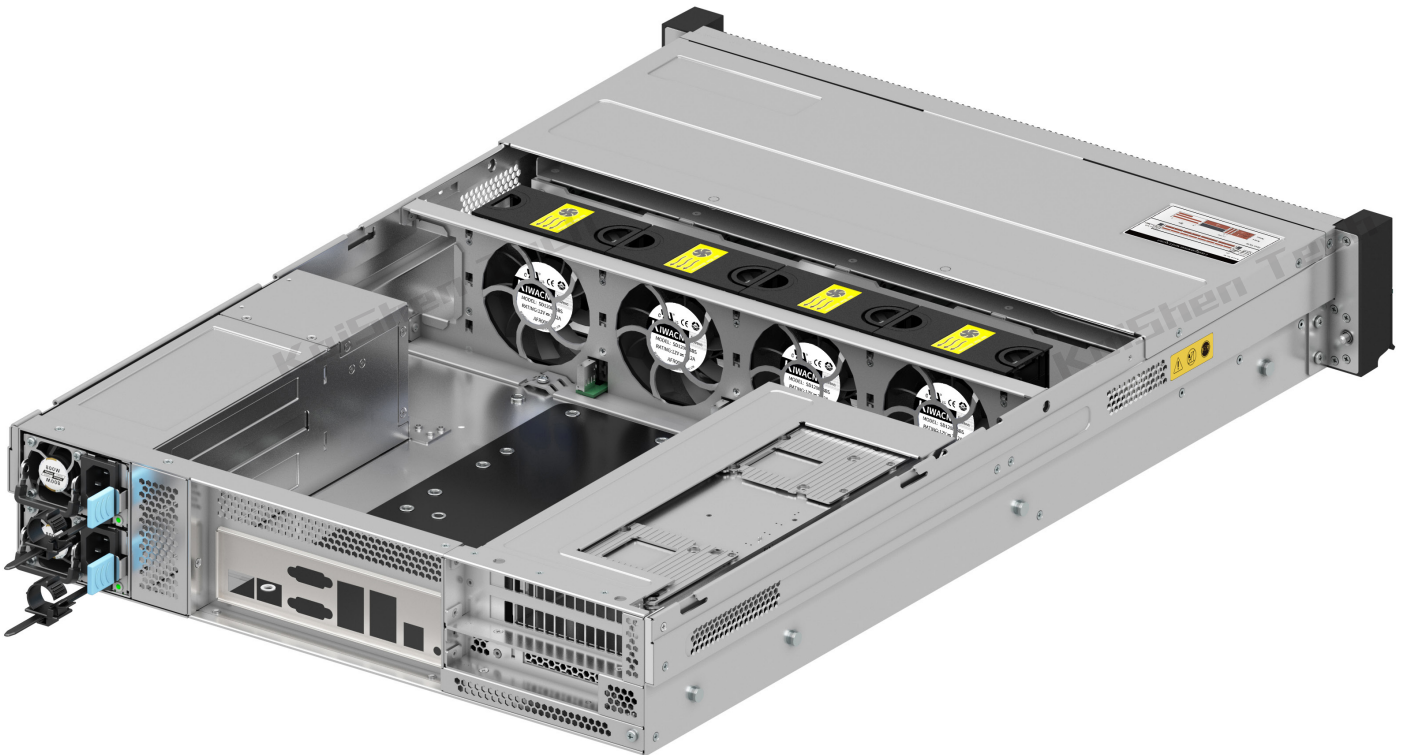

View of Installed Power Supply Unit

Chapter 4 Product Loading

4.1 Product Packaging

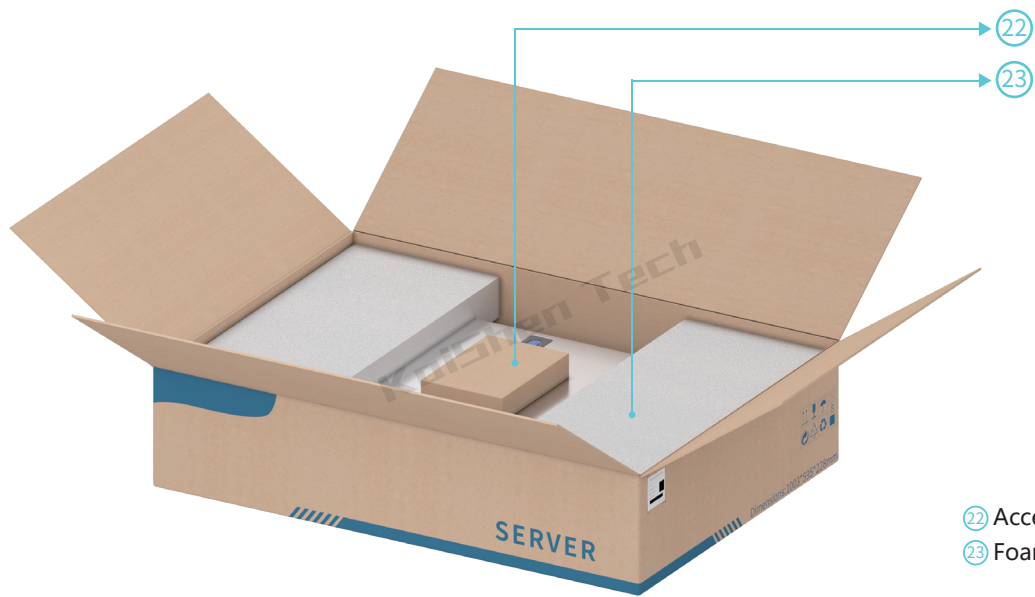

Place it into the suitcase



Seal the suitcase

Chapter 5 Product and Rail Installation

5.1 Install inner rails on both sides of the chassis

5.1.1 Securely attach the inner rail to the side wall of the chassis, and ensure that the inner rail's latch engages with the chassis T-pin.

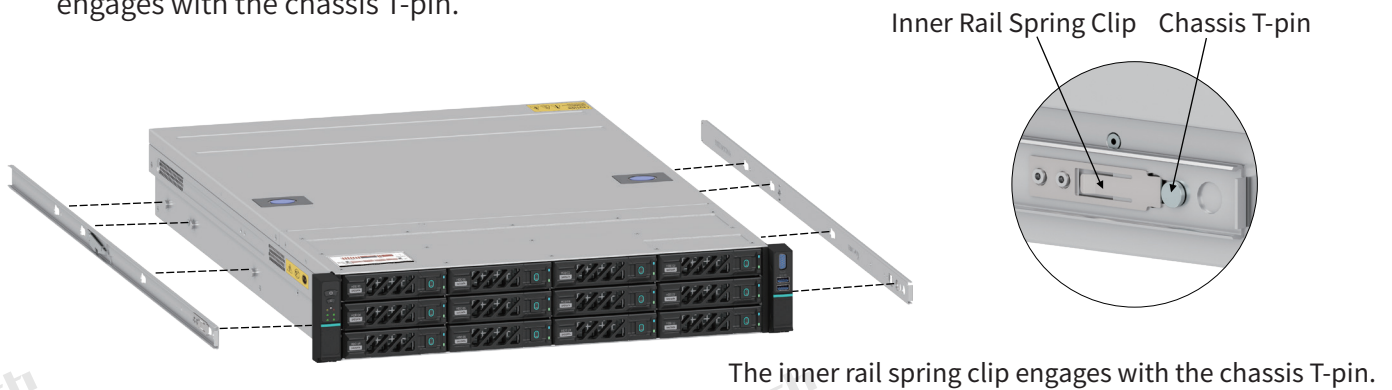

5.2 The chassis is mounted into the rack

(Note: Depending on the weight of the chassis, this step requires the cooperation of 2 to 4 people.)

- 5.2.1 First, move the ball seat to the front end of the middle track. Then, along the G direction, horizontally insert the inner rail of the chassis into the ball seat.
- 5.2.2 When installing the rails, ensure that both sides of the server are kept level, and insert the inner rails simultaneously in a horizontal direction.
- 5.2.3 Ensure that the inner rails have entered the guides and ball seats before proceeding to push them into the chassis.
- 5.2.4 Only release the chassis after confirming that the inner rails have entered at least half of the ball seats.
- 5.2.5 There is a limiting buckle on the inner rail. When pushing it into the second section, you need to flip this buckle to enter the third section for complete closure.
- 5.2.5 If you find that the inner rails have not entered the ball seats, please repeat the above steps. If necessary, you can use your hand to assist the inner rails into the ball seats.
- 5.2.6 Unlock both levers on the sides, then push the chassis to fully close it. Perform at least one complete open and close cycle of the chassis to ensure the slides are correctly installed.

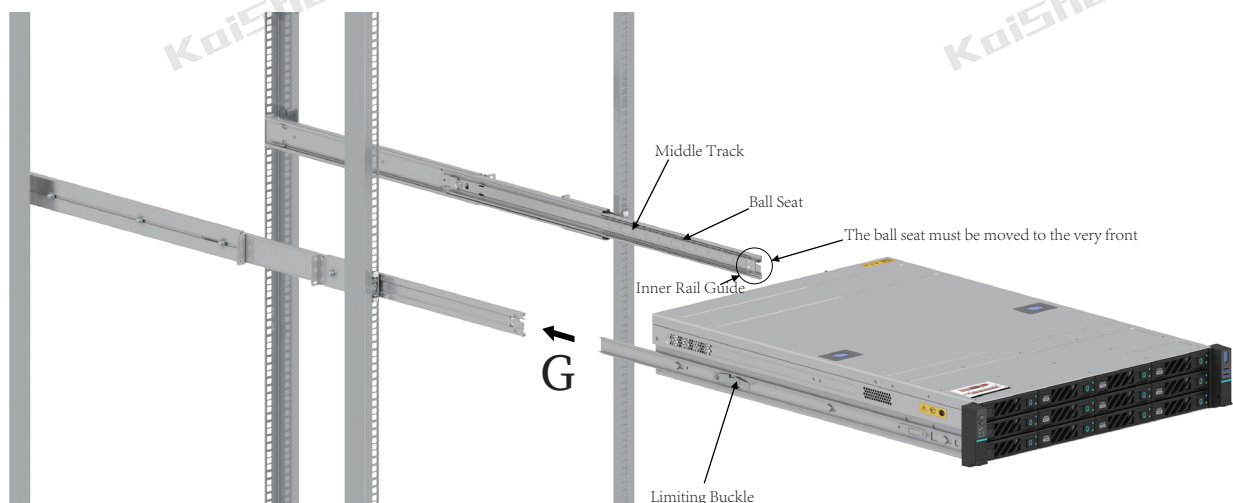





Note: Please make sure to insert horizontally in this direction. Otherwise, it may damage the ball seats and cause the slides to not function properly.

Chapter 6 Accessory Name and Part Number

6.1 Accessories and Material Numbers(Parts Box P/N:0201070009)

No.	Part No.	Name	Photograph	Quantity
01	P/N: 0305010001	2.5-inch hard drive screws (Compatible with 3.5-inch hard drive bay)		56
02	P/N:0305010031	3.5inch hard drive screws		48
03	P/N:0305010124	2.5-inch Hard drive retaining screws		4
04	P/N:0305070003	Motherboard heightening column (Motherboard thickness1.6mm)		12
05	P/N:0305010203	Motherboard screws		12
06	P/N:0202110015	2.5Hard drive holder (2U8)		2
07	P/N:0305010125	Fixed single power/ATX		3
08	P/N:0305010025	Fixed redundancy		8
09	P/N:04.02.0009	hard drive sticker (00-11)		1

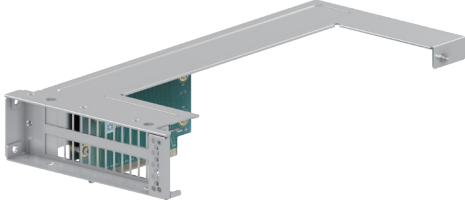
6.2 Optional Accessories List

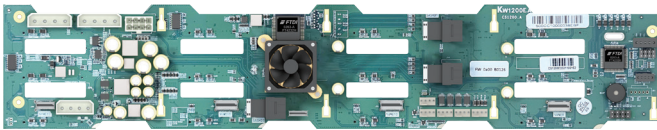
No.	Part No.	Name	Photograph
01	P/N:0304100006	Slide Rail	
02	P/N:0201030001	Earpiece	
03	P/N:0201090001	riser moudle	
04	P/N:0304090001	Wire	
05	P/N:0304090002	SATA Wire	
06	P/N:0302060013	12GB Expansion Backplane	
07	P/N:0201120006	2.5 Moudle	