

# 2U8/2U12L Series Server Chassis

## Product Manual V1.0

# CONTENTS

Chapter 1: Product Introduction .....	02
Chapter 1: Product Introduction .....	02
1.2 Chassis Structure .....	03
1.3 Description of Front Panel and Hard Drive Bay .....	05
1.3.1 Front Panel and Indicator Lights .....	05
1.3.2 Hard Drive Installation and Hard Drive Tray Indicator Light Instructions .....	06
1.4 Hard Drive Backplane .....	07
1.4.1 4-bay direct-connect backplane .....	07
1.4.2 12-bay backplane: 12GB/SAS*8 + Nvme*4 .....	08
1.4.3 12-bay backplane: 12Gb/s Expander .....	09
1.4.4 Adapted motherboard size reference .....	10
Chapter 2: Product Appearance .....	11
2.1 Chassis Structure .....	11
2.1.1 Chassis Diagram .....	11
2.1.2 Server Chassis Images .....	12
2.1.3 Server Dimensions .....	14
Chapter 3: Product Loading and Unloading .....	16
3.1 Removal of the Rear Top Cover .....	16
3.1.1 Disassembly Steps .....	16
3.2 Installation of the Power Supply .....	16
3.2.1 Installation Steps .....	16
3.2.2 Installation of power supply .....	17
Chapter 4: Product Loading .....	19
4.1 Product Packaging .....	19
Chapter 5: Product and Rail Installation .....	20
5.1 Install inner rails on both sides of the chassis .....	20
5.2 The chassis is mounted into the rack .....	20
Chapter 6: Accessory Name and Part Number .....	21
6.1 Chassis accessories list .....	21
6.2 Optional Accessories List .....	22

# Chapter 1: Product Introduction

## 1.1 Product Features

Product Code	K32025	K32021
Chassis Category	2U Rack mount	
Material	SGCC1.2mm(Taiwan)	
MB Form Factor	L6 (448 * 424 mm)	
Dimensions (D*W*H)	760 * 435 * 88.1(mm) 29.92"x 17.12"x 3.47 "	
Drive Bays	3.5"Hot-swap: 8 , 2.5"Hot-swap (Option): 4	3.5"Hot-swap: 12 , 2.5"Hot-swap (Option): 4
PSU Form Factor	2U Single or 1+1 Redundant	
Indicators	1 x Power Status, 1 x HDD Activity , 2 x LAN Activity	
Front Control	1 * Power On/Off , 1 * System Reset, 1 * UID 2 * USB 2.0 , USB3.0 + VGA(Option) , 1 * CD-ROM drive(Option)	
Safety Device	Intrusion Switch (Option)	
Cooling Fans	Middle: 4 x 80 mm (T=38 mm) 15000 PWM, Middle: 4 x 80 mm (T=56 mm) 15000 PWM, (Option)	
Expansion Slots	24pie TO 16pie and 8pice (Option), 24pie TO 3 * 8x (Option)	
HDD Backplane	8-port 12Gb/s - SAS 8-port NVME(Option) 2-port NVME(Option) 2-port 12GB(Option)	12-port 12Gb/s - SAS 12-port 12Gb/s Expander - SAS(option) 8-port three models(Option), 8-port 12gb (Option) 4-port three models(Option), 4-port 12gb(Option) 2-port NVME (Option); 2-port 12GB (Option)
Rack rails	P/N:0304100006(Option)	
Net Weight	11.0kg	
Gross Weight	13.9kg	
Package size(D*W*H)	940x620x230mm	

## 1.2 Chassis Structure

2U8L型结构图:

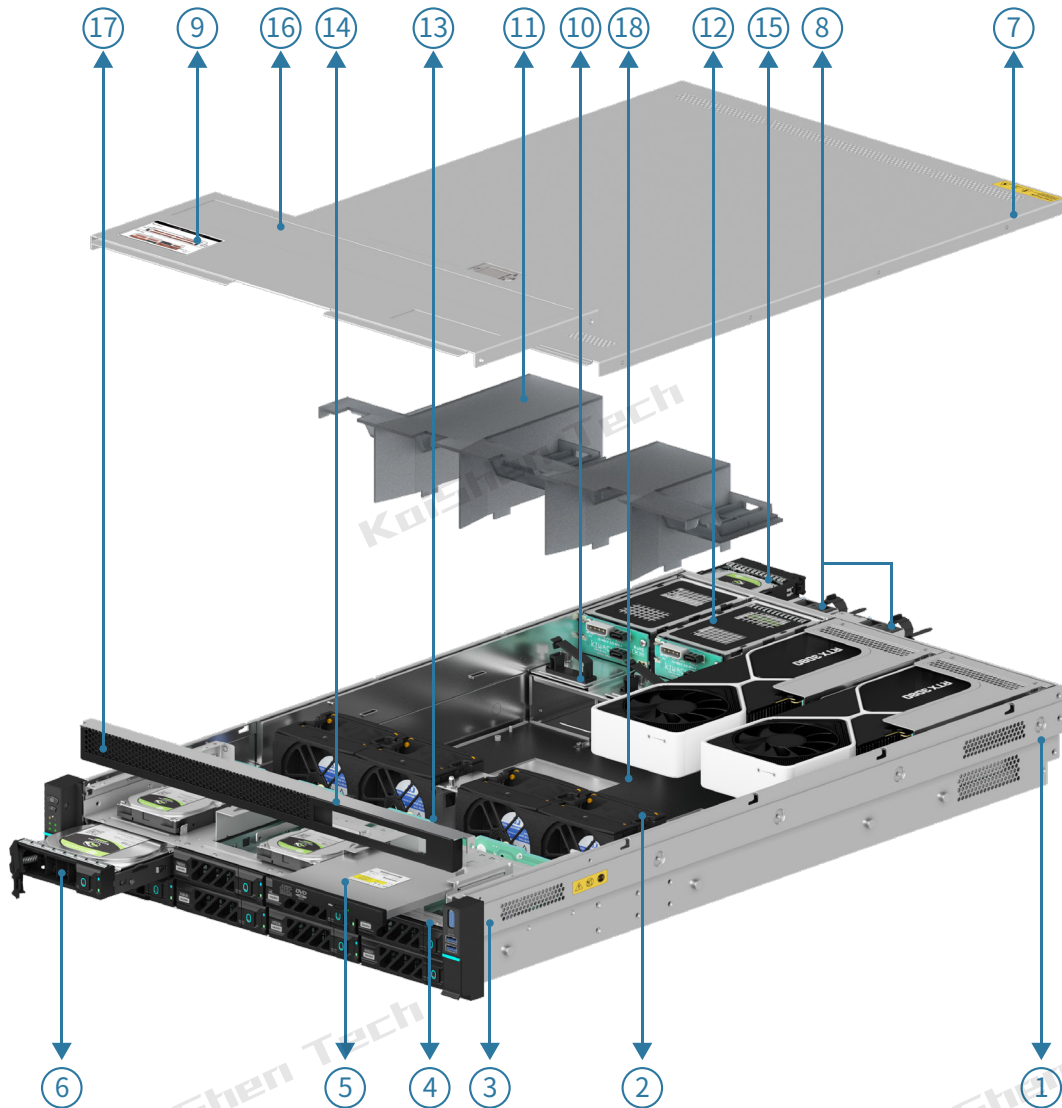

- |  |   |
|--|---|
| 1. Chassis Base  | 10. Power Supply Bracket                    |
| 2. Cooling Fans  | 11. Air Guide Hood                          |
| 3. Right Bracket Assembly  | 12. 2.5 Module                              |
| 4. 2u8 Hard Drive Cage Assembly                                  | 13. Hard Drive Backplane                    |
| 5. CD-ROM drive  | 14. Front Panel                             |
| 6. 3.5-inch Hard Drive Bracket<br>(Supports 2.5-inch Hard Drive) | 15. 2.5-inch Hard Drive<br>Enclosure Module |
| 7. Rear Cover  | 16. Front Cover                             |
| 8. Power Supply  | 17. Left Bracket Assembly                   |
| 9. Chassis Layout Diagram Sticker                                | 18. Gasket                                  |



2U12L型结构图:

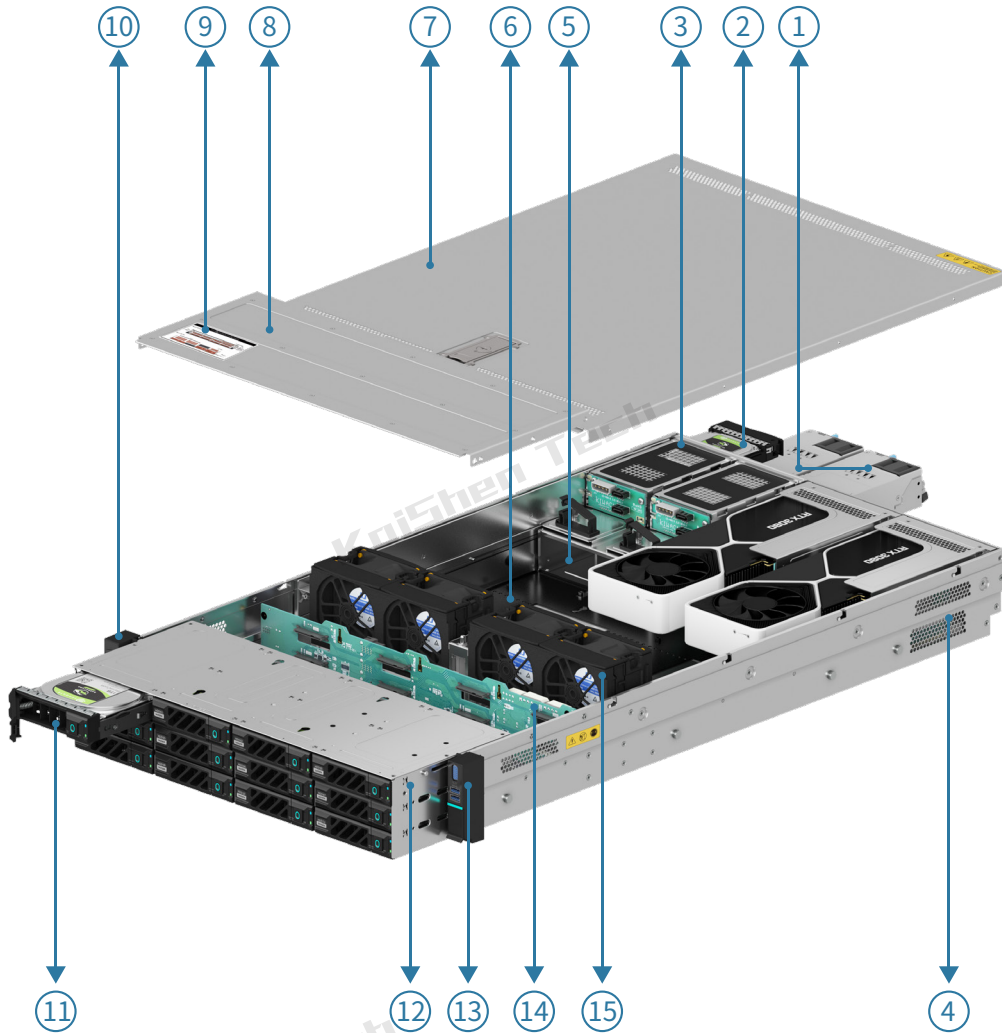

- |  |  |
|--|--|
| 1. Power Supply                                  | 10. Left Bracket Assembly                                    |
| 2. Internal 2.5-inch Hard Drive Mounting Bracket | 11. 3.5-inch Hard Drive Tray (Supports 2.5-inch Hard Drives) |
| 3. 2.5 Module                                    | 12. 2u12 Hard Drive Cage Assembly                            |
| 4. Chassis Base                                  | 13. Right Bracket Assembly                                   |
| 5. Power Supply Bracket                          | 14. Hard Drive Backplane                                     |
| 6. Gasket  | 15. Cooling Fans   |
| 7. Rear Cover                                    | 16. Gasket   |
| 8. Front Cover                                   |  |
| 9. Chassis Layout Diagram Sticker                |  |

## 1.3 Description of Front Panel and Hard Drive Bay

### 1.3.1 Front Panel and Indicator Lights:

2U8L型:



HD00	HD01	HD02	HD03
HD04	HD05	HD06	HD07

2U12L型:



HD00	HD01	HD02	HD03
HD04	HD05	HD06	HD07
HD08	HD09	HD10	HD11

- |                                     |   |                                 |
|-------------------------------------|---|---------------------------------|
| 1. Server Information Label         | 2. Expand VGA Port                      | 3. USB 3.0 x 2                  |
| 4. USB 2.0 x 2                      | 5. Power Button + Power Indicator Light | 6. UID Button + Indicator Light |
| 7. Reset Button                     | 8. HDD Indicator Light                  | 9. Fault Indicator Light        |
| 10. Ethernet Port 1 Indicator Light | 11. Ethernet Port 2 Indicator Light     |                                 |

## Control Panel Buttons and Interface Description:

Power Button	Power button, press once to power on when the system is powered; In the powered-on state, press and hold for 5 seconds to shut down the system.
Reset Button	In the powered-on state, press once to restart the device.
UID Button	In the powered-on state, press once to illuminate the indicator light.

## Control Panel Indicator Light Explanation:

Name	Color	Status	Description
Power Light	Blue	On	The server is in the powered-on state.
UID Light	Blue	On	The server is in the located state.
Fault Indicator Light	Red	On	The server is experiencing a malfunction.
Network 1 Indicator Light	Green	On	The network connection is normal.
Network 2 Indicator Light	Green	On	The network connection is normal.
HDD Indicator Light	Yellow	On	The hard drive is in operational status.

1.3.2 Hard drive installation and hard drive bay indicator light description:

3.5-inch Hard Drive Installation Guide:

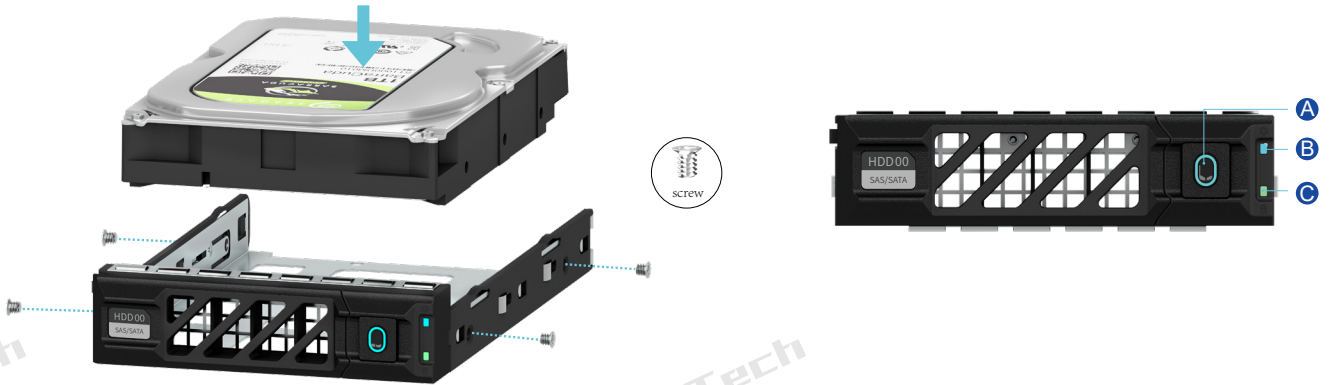

- A. Power On Button
- B. Power Indicator Light
- C. Status Indicator Light

2.5-inch Hard Drive Installation Guide:

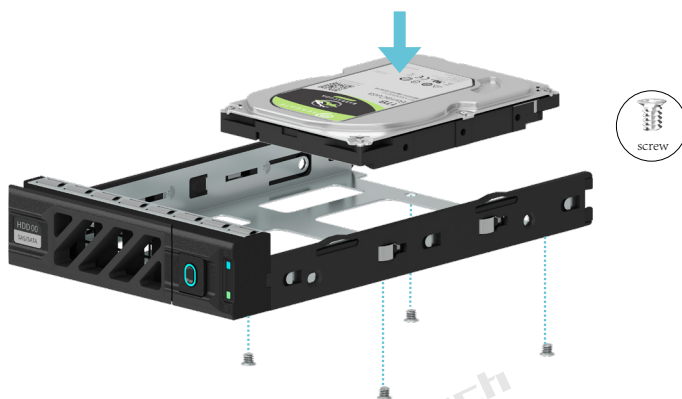

Hard Drive Tray Indicator Light Instructions	
B	Blue: Hard Drive Powered On
	Solid Green: Hard Drive in Position
C	Flashing Green: Hard Drive Activity
	Solid/Flashing Red: Hard Drive Failure

2.5-inch Hard Drive Installation Guide:

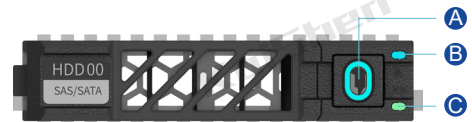
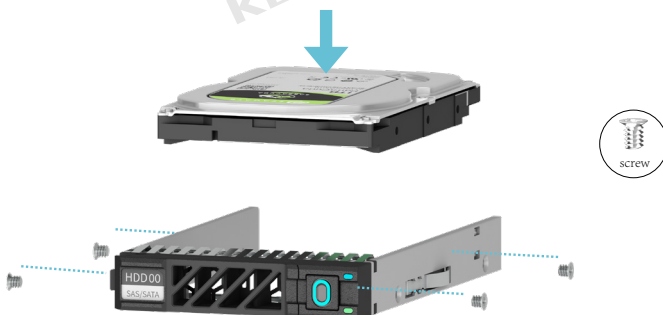

- A. Power On Button
- B. Power Indicator Light
- C. Status Indicator Light

Hard Drive Tray Indicator Light Instructions	
B	Blue: Hard Drive Powered On
	Solid Green: Hard Drive in Position
C	Flashing Green: Hard Drive Activity
	Solid/Flashing Red: Hard Drive Failure

## 1.4 Hard Drive Backplane

### 1.4.1 8-Bay 12GB Direct Attached Backplane

TOP Plane:

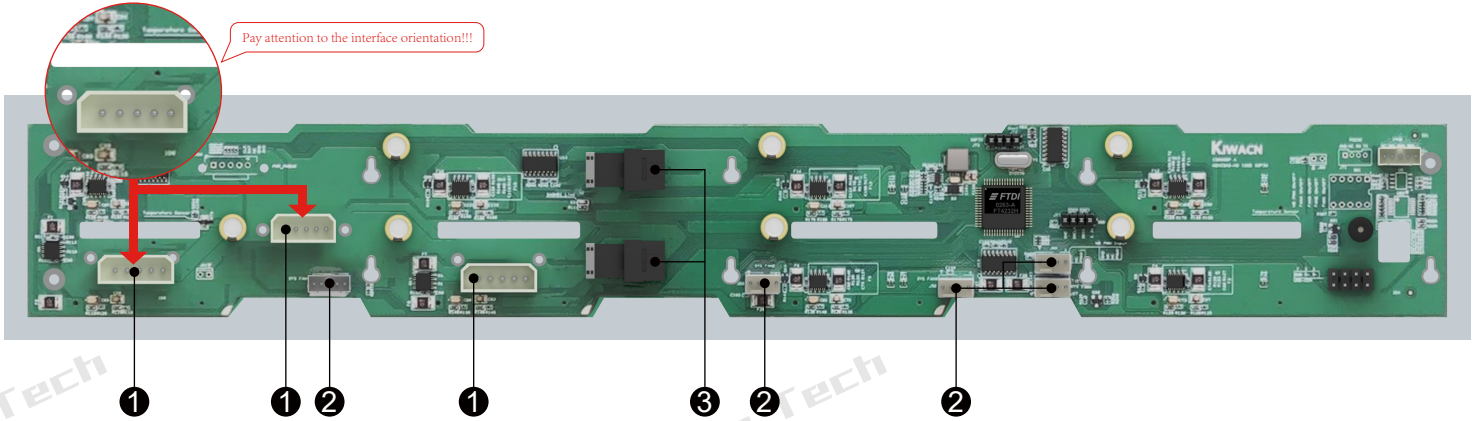

Label	Device Description	Function Description	Location Identifier
1	ATX 4-pin Power Connector	Backplane Power Transmission Connector for 12V Power Supply. <i>(Pay attention to the interface orientation)</i>	J1, J2, J58
2	Fan Connector	Used for 4-pin Fan Connector	SYS FAN1, SYS FAN2, SYS FAN3, SYS FAN4, J69
3	SFF 8643 Connector	Backplane Drive Slot Signal Interface	SASHD1, SASHD2

BOTTOM Plane:

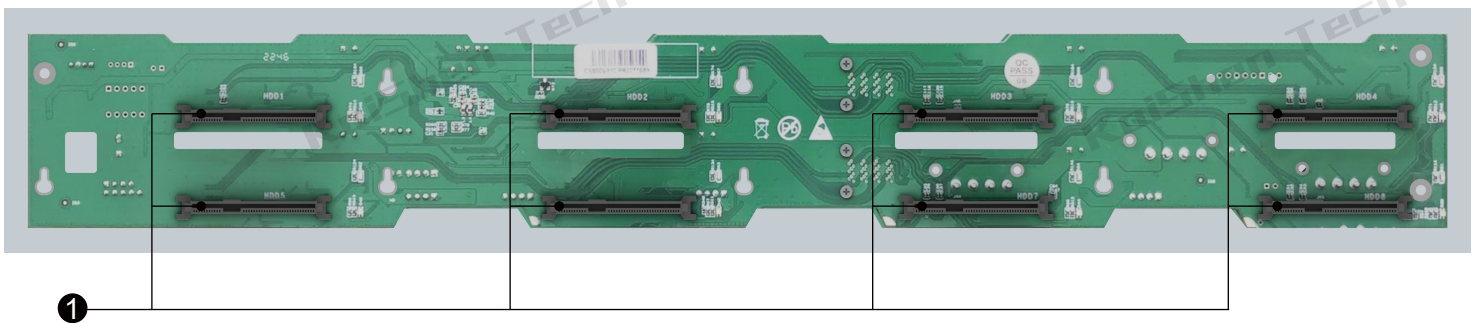

Label	Device Description	Function Description	Function Description
1	SAS/SATA Hard Drive Connector	1.Supports up to 12G/b SAS Hard Drives; 2.Supports up to 6G/b SATA Hard Drives; 3.Supports Hot-Swappable SAS/SATA Hard Drives.	HDD1, HDD2,HDD3, HDD4, HDD5,HDD6, HDD7,HDD8



1.4.2 12-bay backplane: 12GB/SAS\*8 + Nvme\*4

TOP Plane:

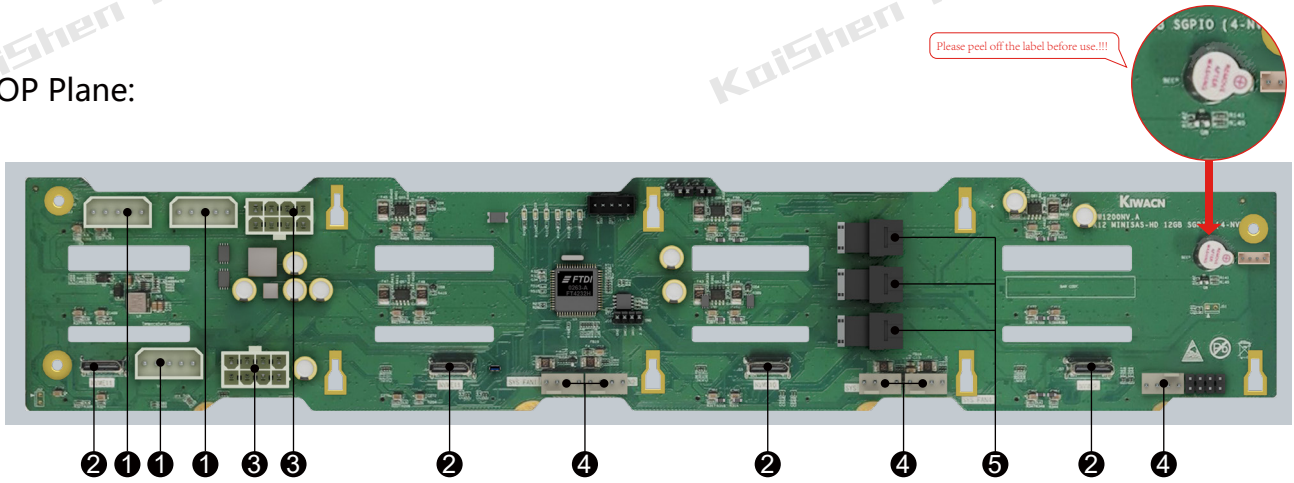

Label	Device Description	Function Description	Location Identifier
1	ATX 4P Power Connector	Backplane Power Transmission Connector, used for 12V power supply transmission. <b>(Pay attention to the orientation of the interface!!! And do not connect it simultaneously with the large 8-pin connector (③)!!!)</b>	J2, J4, J6
2	Nvme 8611Connector	Nvme 3.0 Connector(Optional)	NVME9, NVME10, NVME11, NVME12
3	8P Power Connector	Backplane Power Transmission Connector, used for 12V power supply transmission <b>Note: Cannot be connected simultaneously with the large 8-pin connector (①)</b>	J5, J60
4	Fan Power Connector	For use with 4-pin fan connector	SYS FAN1, SYS FAN2, SYS FAN3, SYS FAN4
5	8SFF8643 Connector	Backplane Drive Slot Signal Interface	SASHD1, SASHD2, SASHD3

TOP Plane:

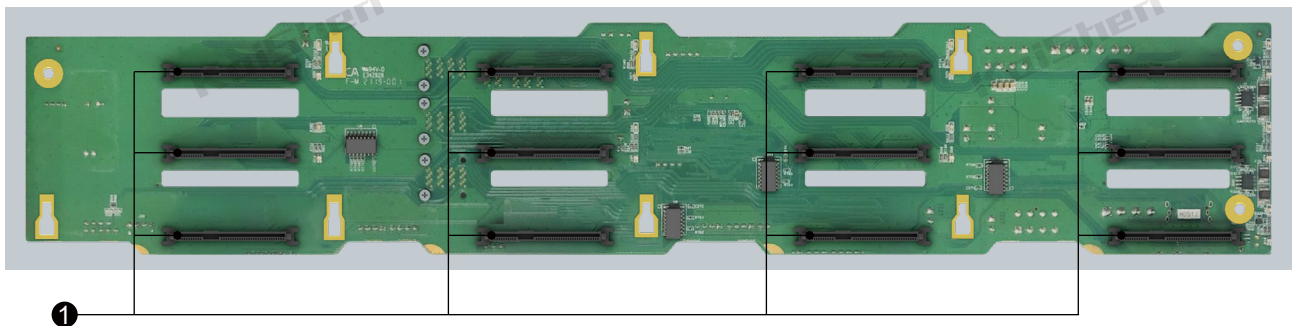

Label	Device Description	Function Description	Function Description
1	SAS/SATA Hard Drive Connector	1.Supports up to 12G/b SAS Hard Drives; 2.Supports up to 6G/b SATA Hard Drives; 3.Supports Hot-Swappable SAS/SATA Hard Drives.	HDD1, HDD2, HDD3, HDD4, HDD5, HDD6, HDD7, HDD8, HDD9, HDD10, HDD11, HDD12

### 1.4.3 12-Bay Backplane: 12Gb/s Expander

TOP Plane:

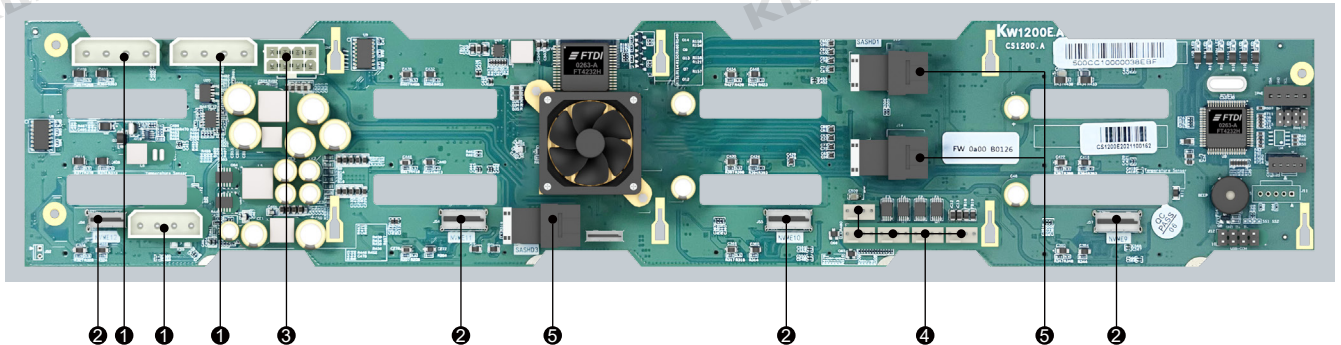

Label	Device Description	Function Description	Location Identifier
1	ATX 4P Power Connector	Backplane Power Transmission Connector, used for 12V power supply transmission. <i>(Pay attention to the orientation of the interface!!! And do not connect it simultaneously with the large 8-pin connector (③)!!!)</i>	J2, J4, J6
2	Nvme 8611Connector	Nvme 3.0 Connector(Optional)	NVME9, NVME10, NVME11, NVME12
3	8P Power Connector	Backplane Power Transmission Connector, used for 12V power supply transmission <i>(Note: Cannot be connected simultaneously with the large 8-pin connector (①)!!!)</i>	J5
4	Fan Power Connector	For use with 4-pin fan connector	J44, SYS FAN1, SYS FAN2, SYS FAN3, SYS FAN4
5	8SFF8643 Connector	Backplane Drive Slot Signal Interface	SASHD1, SASHD2, SASHD3

BOTTOM Plane:

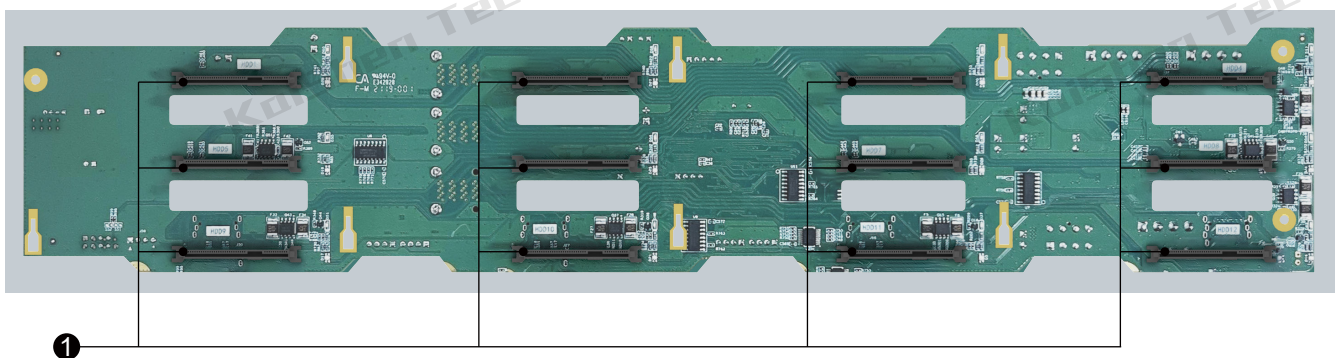

Label	Device Description	Function Description	Function Description
1	SAS/SATA Hard Drive Connector	1.Supports up to 12G/b SAS Hard Drives; 2.Supports up to 6G/b SATA Hard Drives; 3.Supports Hot-Swappable SAS/SATA Hard Drives.	HDD1, HDD2, HDD3, HDD4, HDD5, HDD6, HDD7, HDD8, HDD9, HDD10, HDD11, HDD12

1.4.4 Adapted motherboard size reference

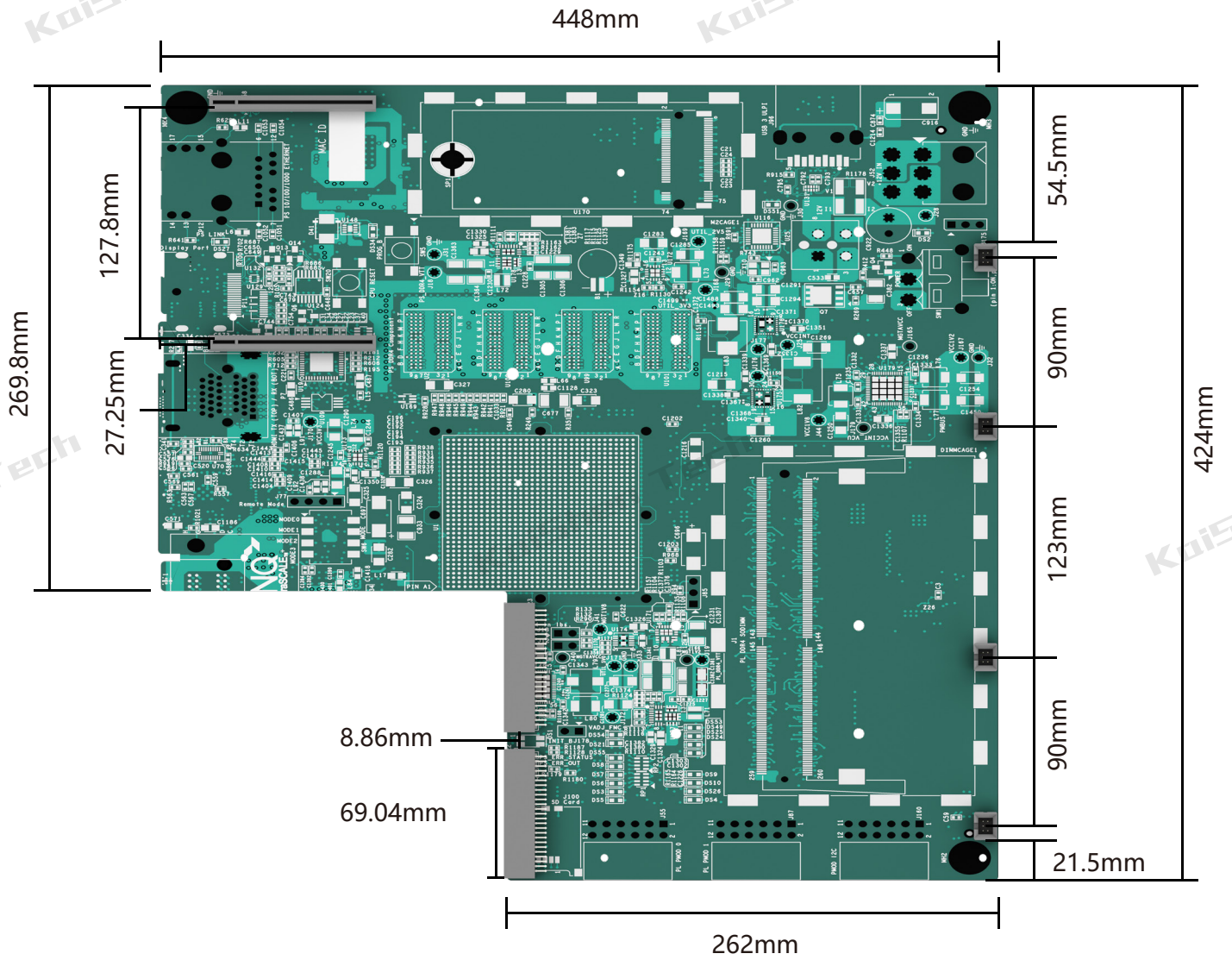



# Chapter 2: Product Appearance

## 2.1 Chassis Structure

### 2.1.1 Chassis Diagram

2U8L:

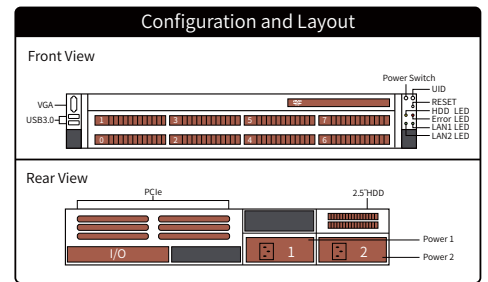
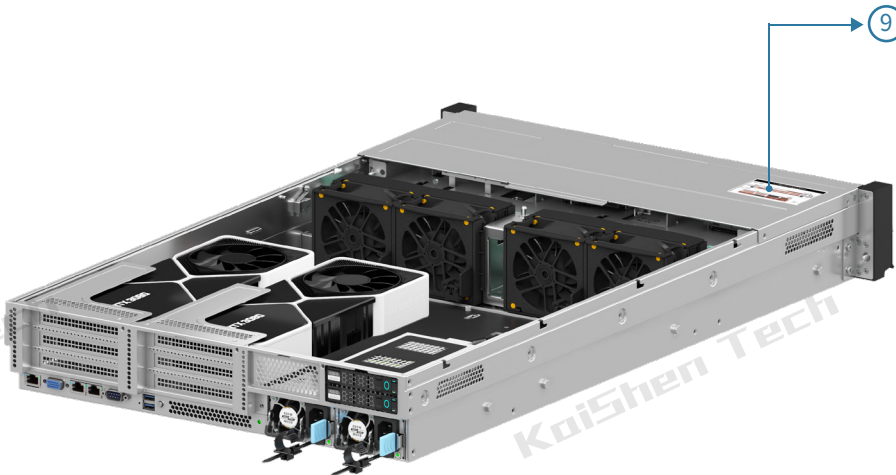

⑨ Chassis Layout Diagram Sticker



2U12L:

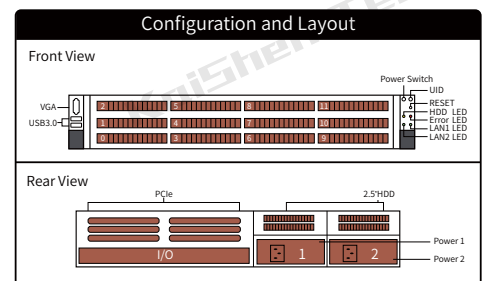
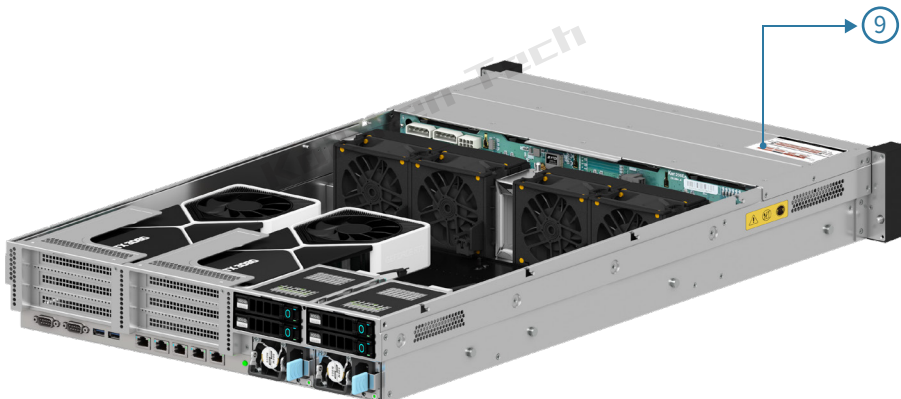

⑨ Chassis Layout Diagram Sticker

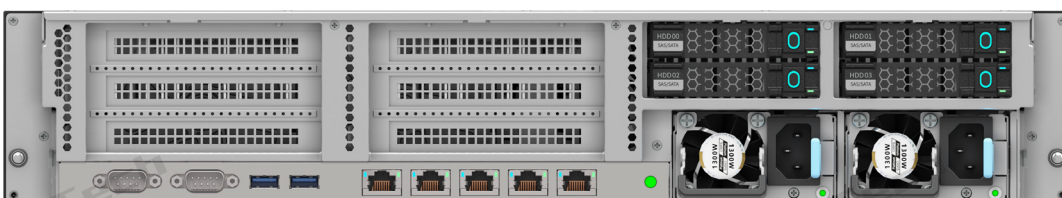

## 2.1.2 Server Chassis Images

2U8L:



Front View



45° Side View



45° Rear View

## 2.1.2 Server Chassis Images

2U12L:



Front View



45° Side View



45° Rear View

### 2.1.3 Server Dimensions

2U8L:

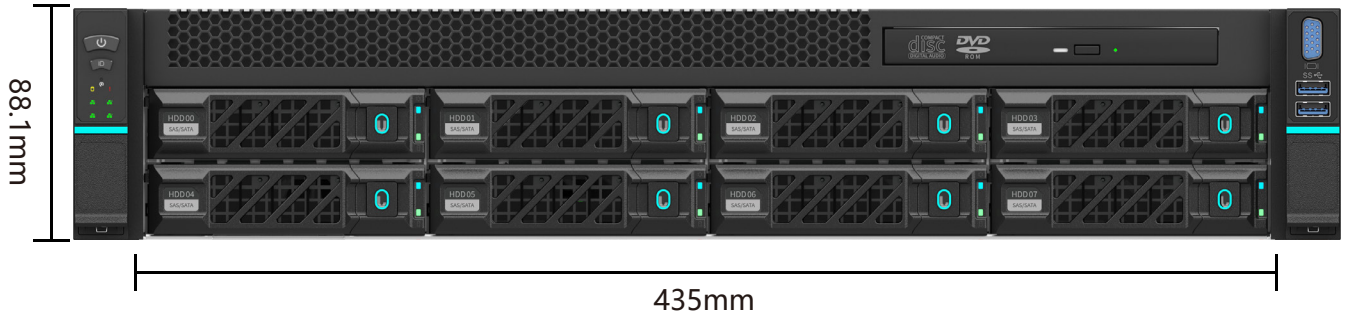

Front View (Dimensions)

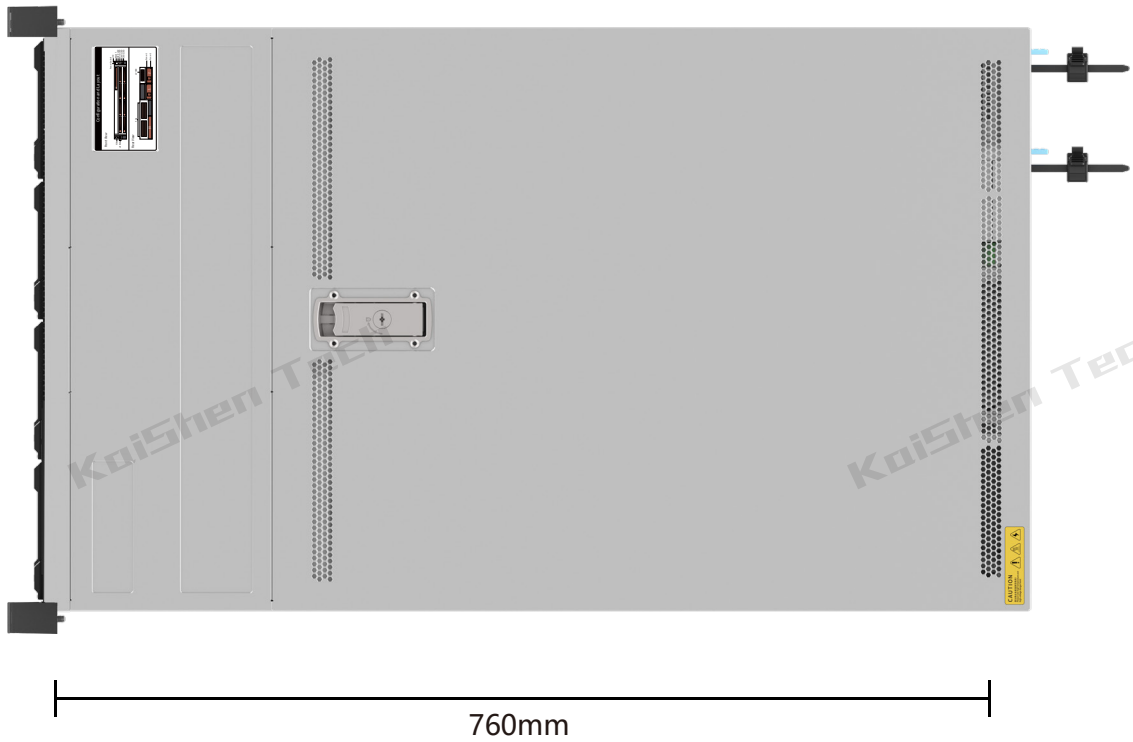

Top View (Dimensions)

2U12L:

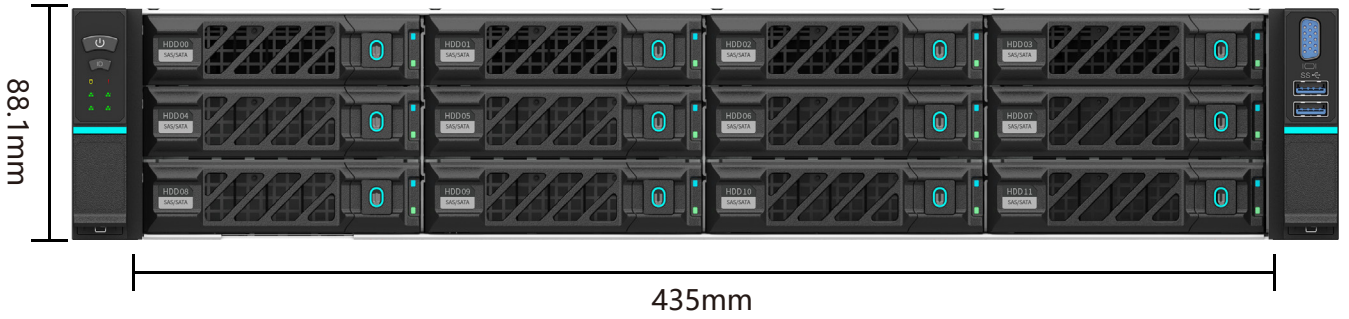

Front View (Dimensions)

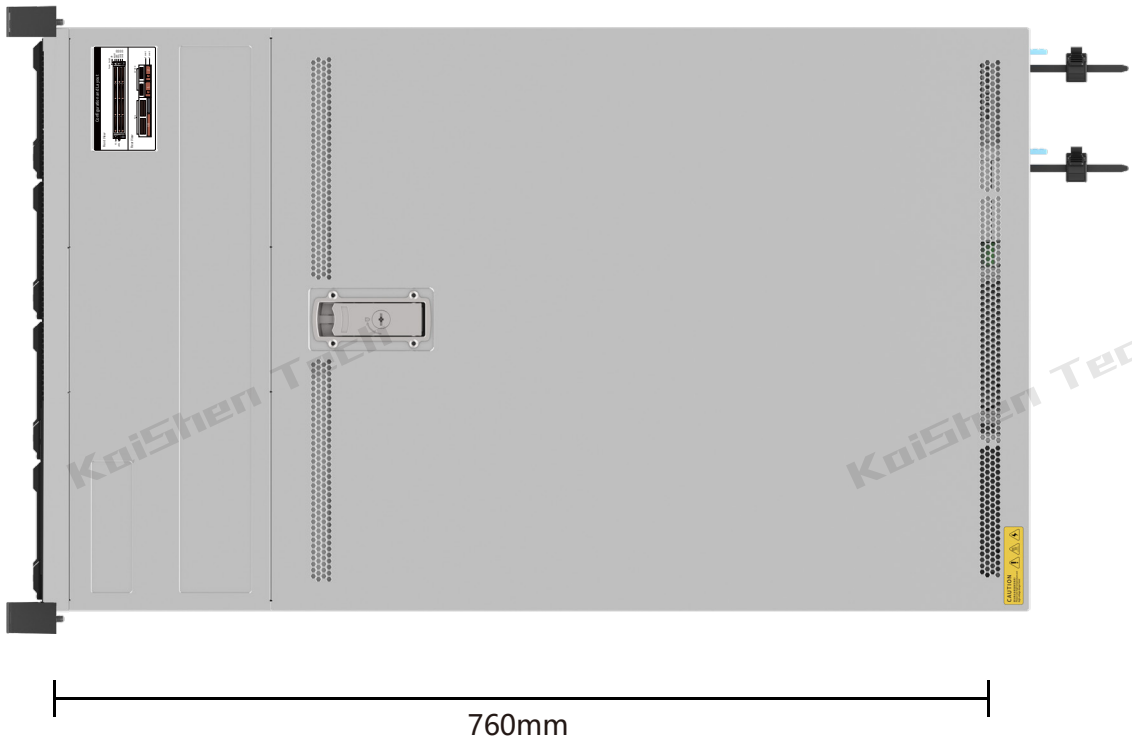

Top View (Dimensions)



## Chapter 3 Product Loading and Unloading

### 3.1 Installation of Optical Drive

#### 3.1.1 Steps of Installing the Optical Drive:



Install the drive bay bracket in the direction of the arrows and secure it with the locking screws.

### 3.2 Removal of the Rear Top Cover

#### 3.2.1 Disassembly Steps:

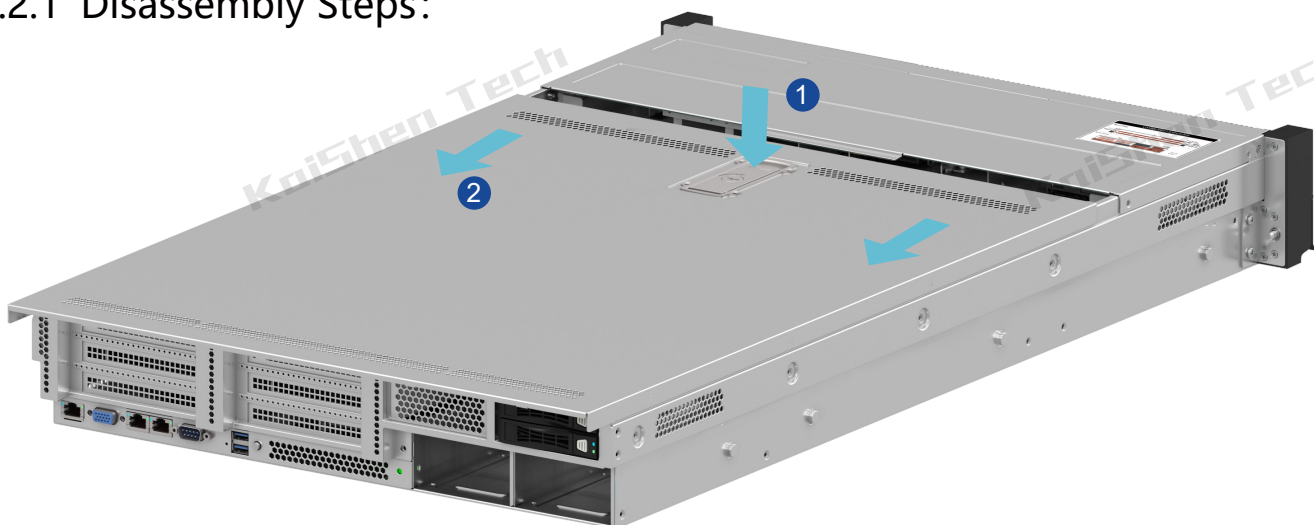

1. Pull the latch as indicated in the diagram to release the lock;
2. Slide the top cover backward in the direction of the arrow;

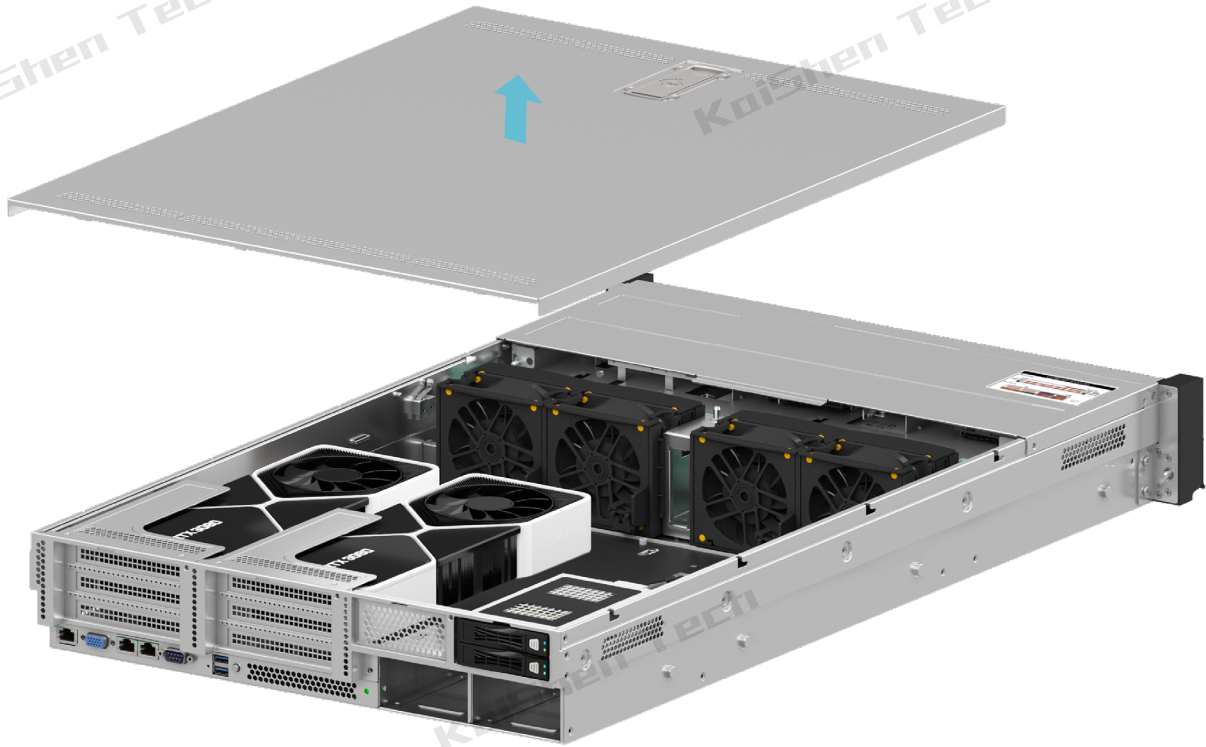

Lift the top cover upward in the direction of the arrow to remove it.

### 3.2.2 Step: Install the power supply

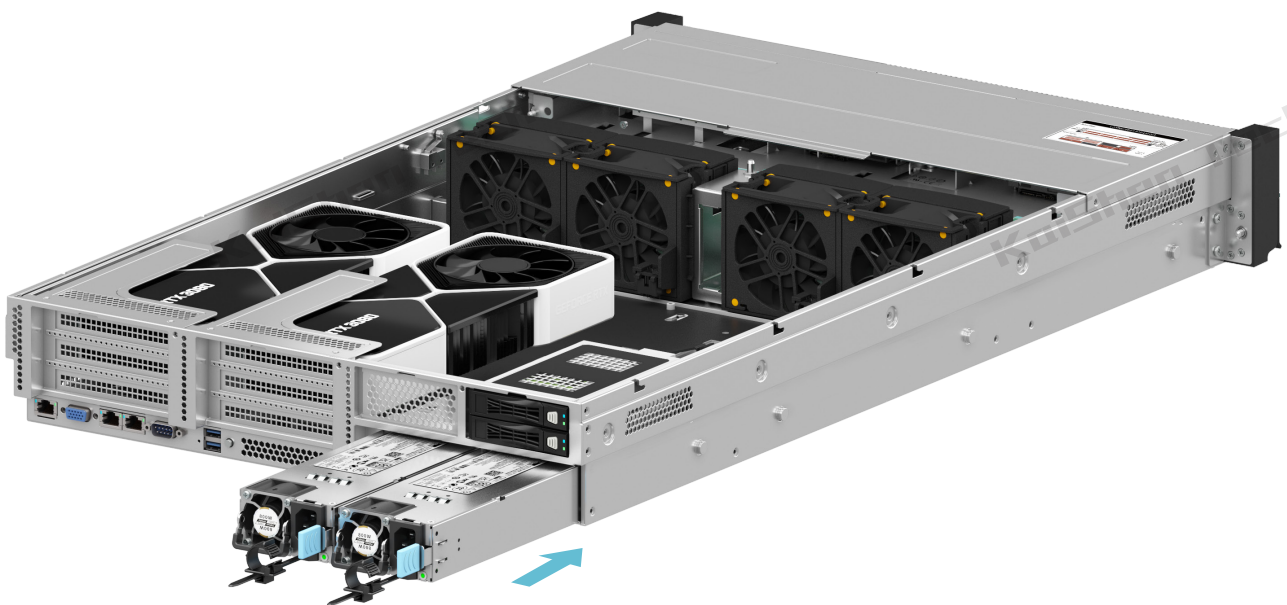

Insert power supply modules 1 and 2 into the power supply frame separately.

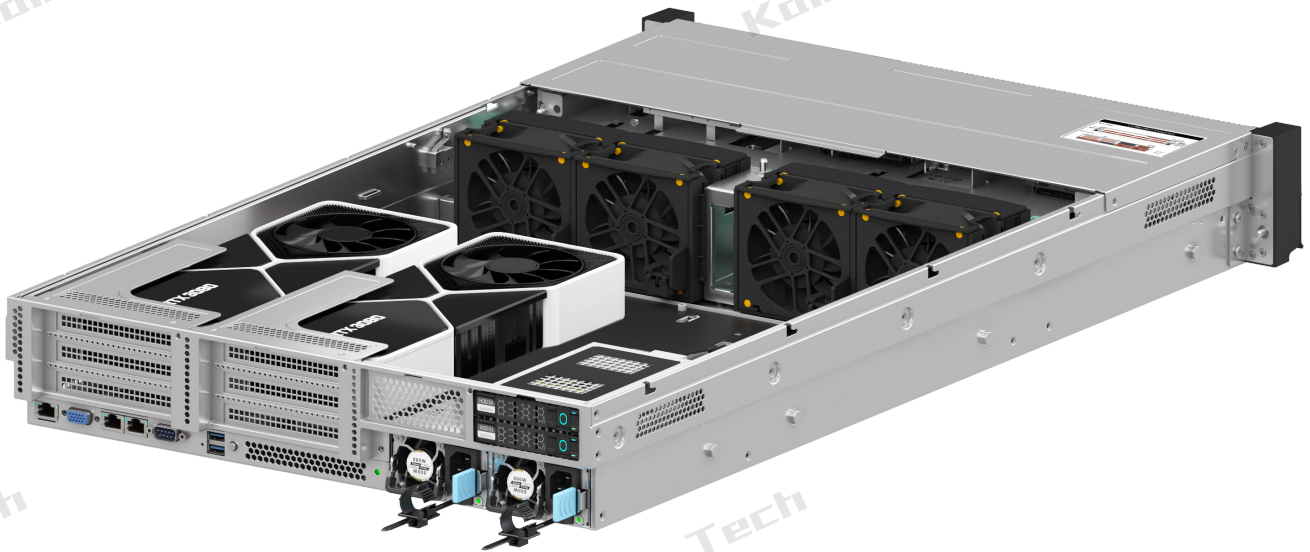

Installation completed - Image of the power supply in place



## Chapter 4 Product Loading

### 4.1 Product Packaging

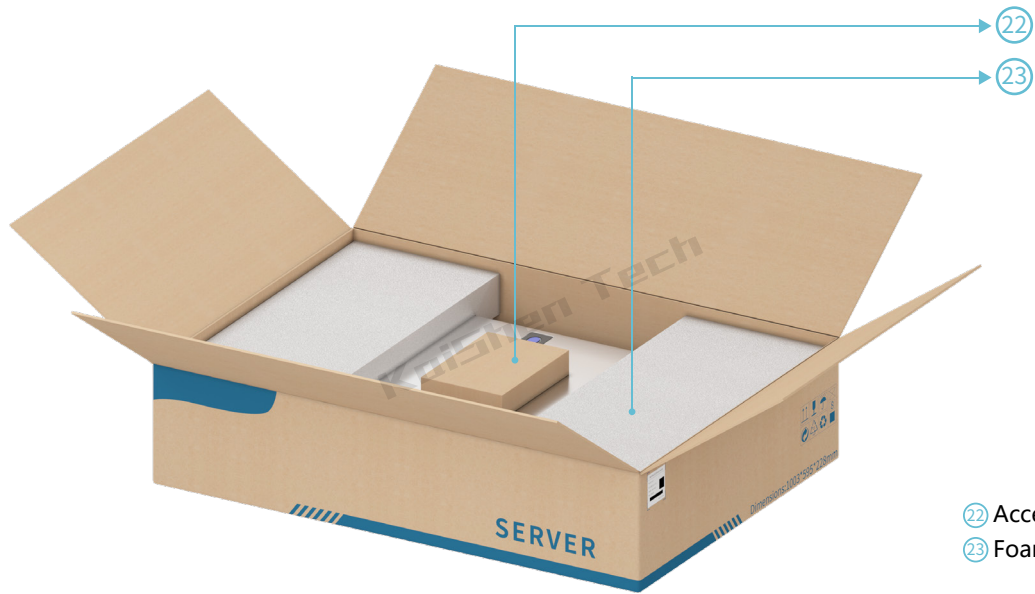

Place it into the suitcase



Seal the suitcase

## Chapter 5 Product and Rail Installation

### 5.1 Install inner rails on both sides of the chassis

5.1.1 Securely attach the inner rail to the side wall of the chassis, and ensure that the inner rail's latch engages with the chassis T-pin.



The inner rail spring clip engages with the chassis T-pin.

### 5.2 The chassis is mounted into the rack

(Note: Depending on the weight of the chassis, this step requires the cooperation of 2 to 4 people.)



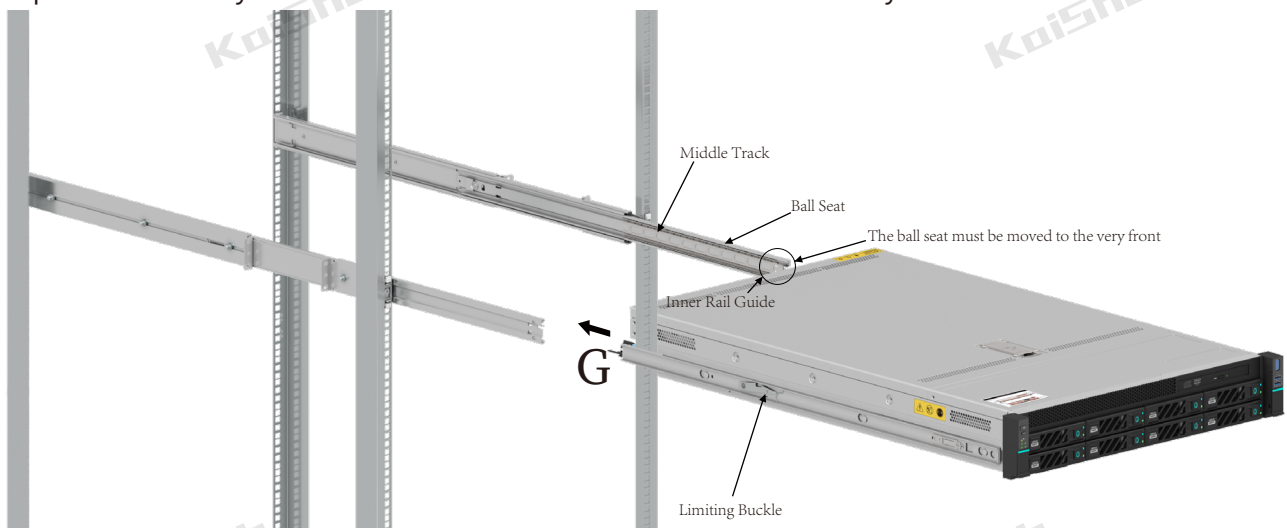

- 5.2.1 First, move the ball seat to the front end of the middle track. Then, along the G direction, horizontally insert the inner rail of the chassis into the ball seat.
- 5.2.2 When installing the rails, ensure that both sides of the server are kept level, and insert the inner rails simultaneously in a horizontal direction.
- 5.2.3 Ensure that the inner rails have entered the guides and ball seats before proceeding to push them into the chassis.
- 5.2.4 Only release the chassis after confirming that the inner rails have entered at least half of the ball seats.
- 5.2.5 There is a limiting buckle on the inner rail. When pushing it into the second section, you need to flip this buckle to enter the third section for complete closure.
- 5.2.5 If you find that the inner rails have not entered the ball seats, please repeat the above steps. If necessary, you can use your hand to assist the inner rails into the ball seats.
- 5.2.6 Unlock both levers on the sides, then push the chassis to fully close it. Perform at least one complete open and close cycle of the chassis to ensure the slides are correctly installed.









Note: Please make sure to insert horizontally in this direction. Otherwise, it may damage the ball seats and cause the slides to not function properly.

## Chapter 6 Accessory Name and Part Number

### 6.1 Accessories and Material Numbers

No.	Part No.	Name	Photograph	Quantity
01	P/N:04.02.0009	hard drive sticker (00-11)		1
02	P/N:?????????????	3.5inch hard drive screws		?
03	P/N:?????????????	power cable		1
04	P/N:?????????????	SATA cable		1
05	P/N:?????????????	NVME cable		1

## 6.2 Optional Accessories List

No.	Part No.	Name	Photograph
01	P/N:0304100006	slide rail	
02	P/N:0304090001	8654 cable	
03	P/N:0201120006	2.5 SATA moudle	
04	P/N:0201120007	2.5 NVME moudle	
05	P/N:???????????????	8038 fan moudle	
06	P/N:0302050004	rasier card	
07	P/N:0302050005	rasier card	