

4U450-BAY SERIES SERVER CHASSIS

Product Manual V1.0

CONTENTS

Chapter 1: Product Introduction	00
1.1 Product features	02
1.2 Chassis Structure	03
1.3 Description of Front Panel and Hard Drive Bay	05
1.3.1 Front Panel and Indicator Lights	05
1.3.2 Hard Drive Installation and Hard Drive Tray Indicator Light Instructions	06
1.4 Hard Drive Backplane	07
1.4.1 4-Bay Direct Attached Backplane	07
Chapter 2: Product Appearance	08
2.1 Chassis Structure	08
2.1.1 Chassis Diagram	08
2.1.2 Server Chassis Images	10
2.1.3 Server Dimensions	13
Chapter 3: Product Loading and Unloading	16
3.1 Removal of the Rear Top Cover	16
3.1.1 Disassembly Steps	16
3.2 Installation of the Power Supply	16
3.2.1 Installation Steps	16
Chapter 4: Product Loading	19
4.1 Product Packaging	19
Chapter 5: Product and Rail Installation	20
5.1 Install inner rails on both sides of the chassis (model K14005)	20
5.2 The chassis is mounted into the rack	20
5.3 Install inner rails on both sides of the chassis (model K24006&K14007)	21
5.4 The chassis is mounted into the rack	21
Chapter 6: Accessory Name and Part Number	22
6.1 Chassis Accessories List	22
6.2 Optional Accessories List	24

Chapter 1: Product Introduction

1.1 Product Features

Product Code	K14005	K34006	K14007
Chassis Category	4U Rack mount		
Material	SGCC1.2mm(Taiwan)		
MB Form Factor	Super Extended ATX (15.12" x 13.2")	Extended ATX (12"x13")	
Dimensions (D*W*H)	450x435x177 (mm) 17.72" x 17.12" x 6.97"		
Drive Bays	Internal 3.5": 2	3.5" Hot-swap: 4 Internal 2.5": 2	Internal 2.5": 2
PSU Form Factor	Redundant power supply board 2000W Redundant power supply board 3000W(Optional)	2U Single or ATX or 1+1 Redundant	
Indicators	1 x Power Status, 1 x HDD Activity , 2 x LAN Activity		
Front Control	Power On/Off, System Reset, 2 x USB 2.0		
Cooling Fans	Middle: 8x 8038, PWM Rear inside: 2 x 8025 Rear hanger 2*8038	Middle: 3x 12038 Rear inside: 2 x 8025(Optional), Rear hanger 2*8038 (Option)	
Expansion Slots	11 x Low Profile	8 x Low Profile	
Riser card module	NO	6Gb/s SAS/SATA, 12Gb/s Mini-SAS(Optional) Nvme(Optional)	NO
Rack rails	P/N:0304100005(Optional)		
Net Weight	10.4kg	10.8kg	9.7kg
Gross Weight	12.7kg	13.1kg	12.0kg
Package size(D*W*H)	620x600x270mm		

1.2 Chassis Structure

K14007 & K34006 structure:

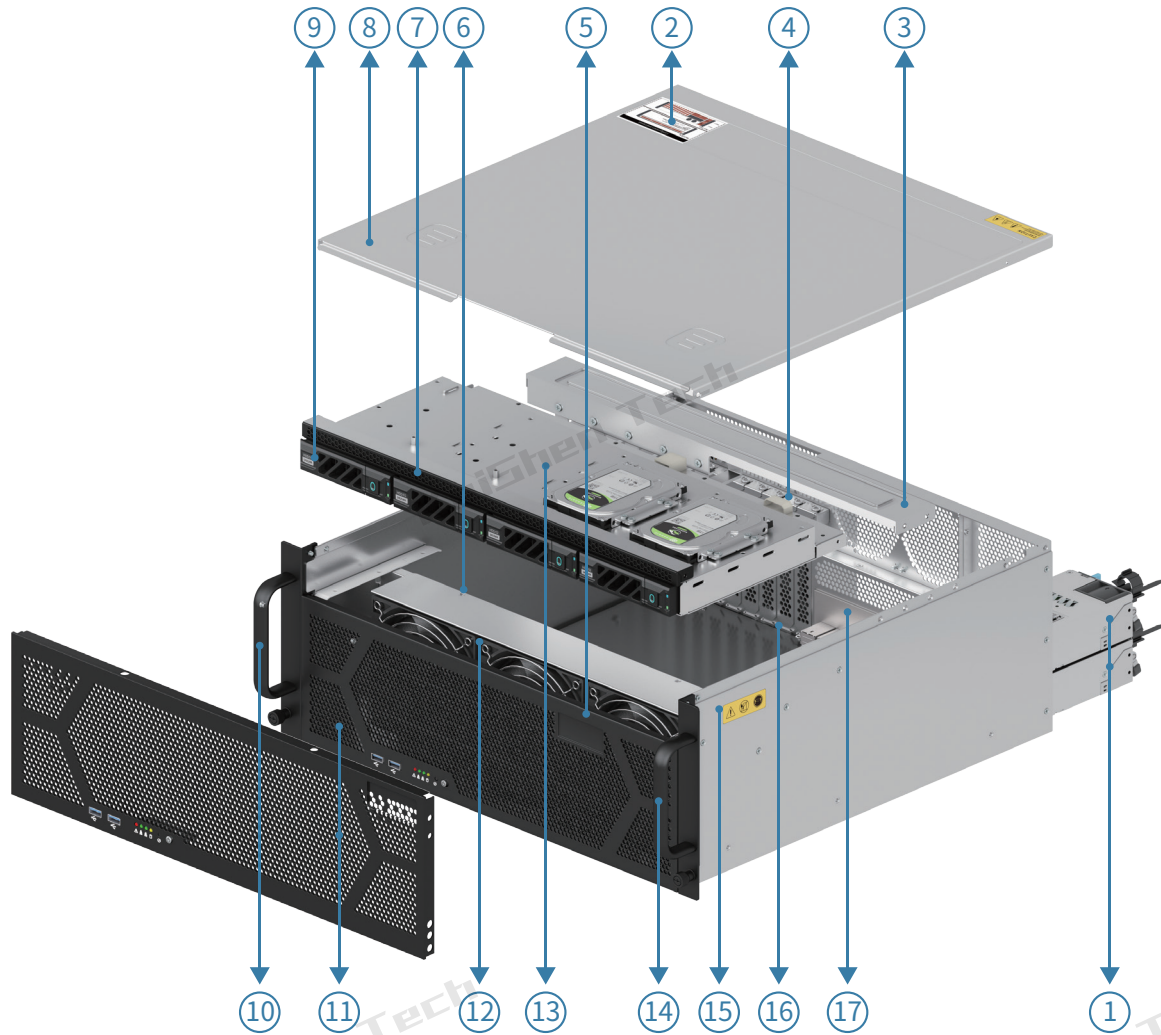

- | | |
|--|----------------------------------|
| 1. Power Supply | 10. Left Bracket Assembly |
| 2. Chassis Layout Diagram Sticker | 11. Front Panel(Choose One) |
| 3. Graphics Card Bracket | 12. Cooling Fans |
| 4. Standard 8 PCIe Expansion Slots | 13. 1u4 Hard Drive Cage Assembly |
| 5. logo Sticker | 14. Right Bracket Assembly |
| 6. Fan Wall | 15. Chassis Base |
| 7. Hard Drive Cage Front Panel | 16. Spacer |
| 8. Front Cover | 17. I/O Shield |
| 9. 3.5-inch Hard Drive Tray
(Supports 2.5-inch Hard Drives) | |

K14005 structure:

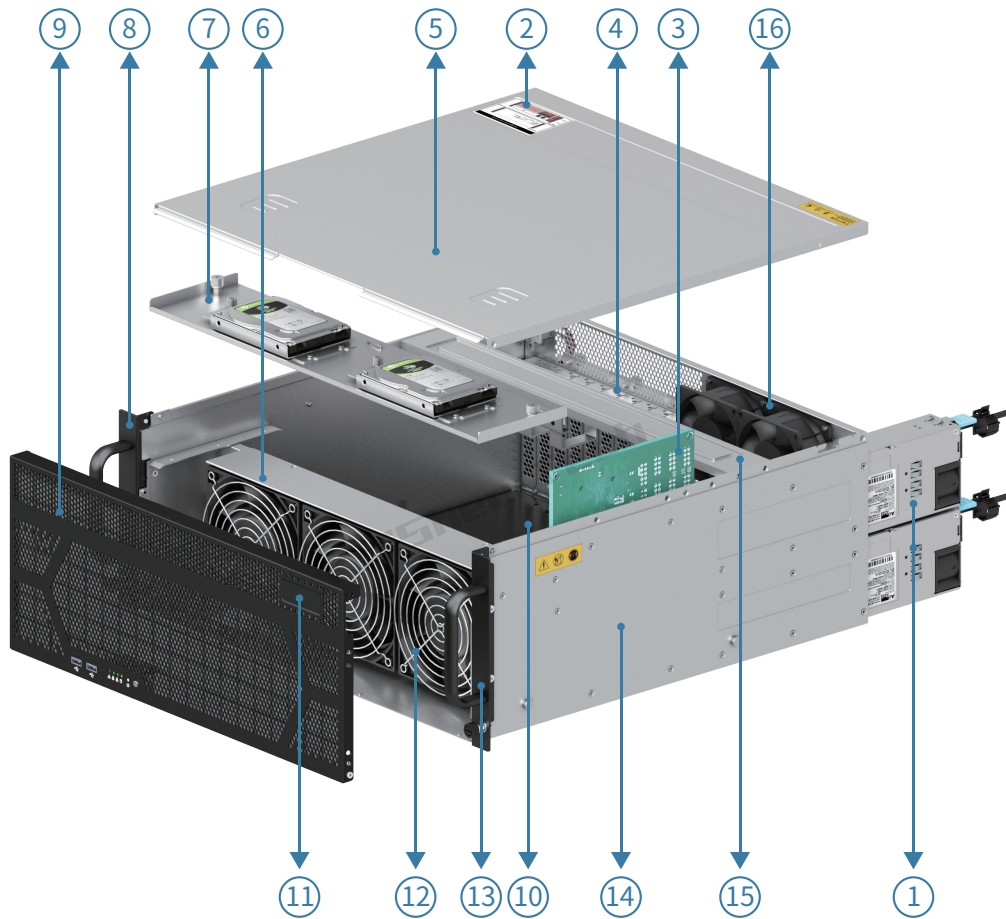

- | | |
|-------------------------------------|----------------------------|
| 1. Power | 10. Cooling Fans |
| 2. Chassis Layout Diagram Sticker | 11. logo Sticker |
| 3. Hard Drive Cage Front Panel | 12. Cooling Fans |
| 4. Standard 11 PCIe Expansion Slots | 13. Right Bracket Assembly |
| 5. Front Cover | 14. Chassis Base |
| 6. Fan Wall | 15. Graphics Card Bracket |
| 7. Hard Drive Tray | 16. Cooling Fans |
| 8. Left Bracket Assembly | |
| 9. Front Panel | |

1.3 Description of Front Panel and Hard Drive Bay

1.3.1 Front Panel and Indicator Lights:

Model K14007:

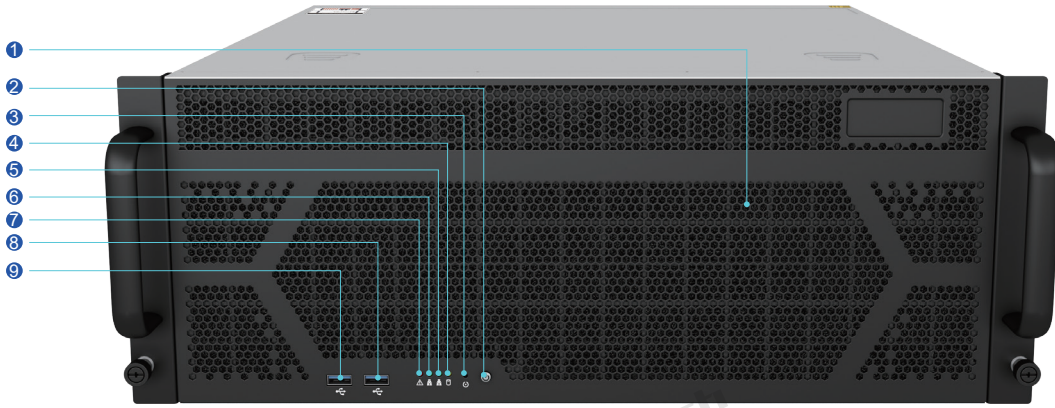

Model K14005:

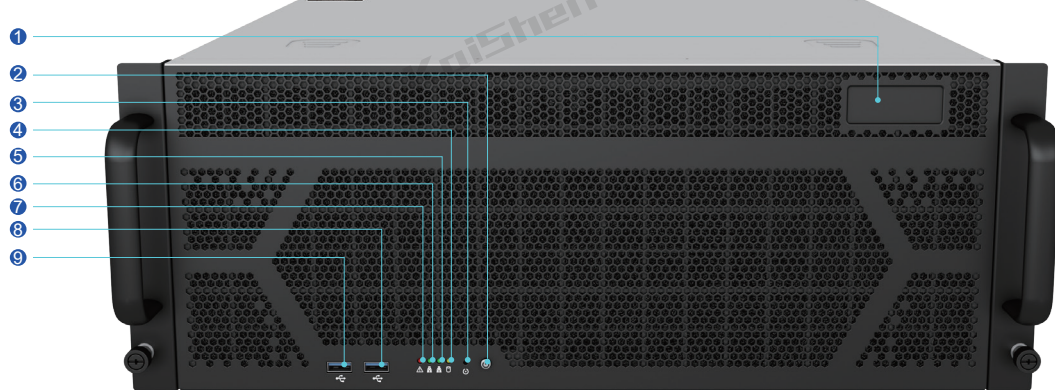

- | | | |
|-----------------------------------|----------------------------------|----------------------------------|
| 1. Chassis Layout Diagram Sticker | 2. Power Button | 3. Reset Button |
| 4. HDD Indicator Light | 5. Ethernet Port Indicator Light | 6. Ethernet Port Indicator Light |
| 7. Warning Indicator Light | 8. USB Connector | 9. USB Connector |

Model K24006:

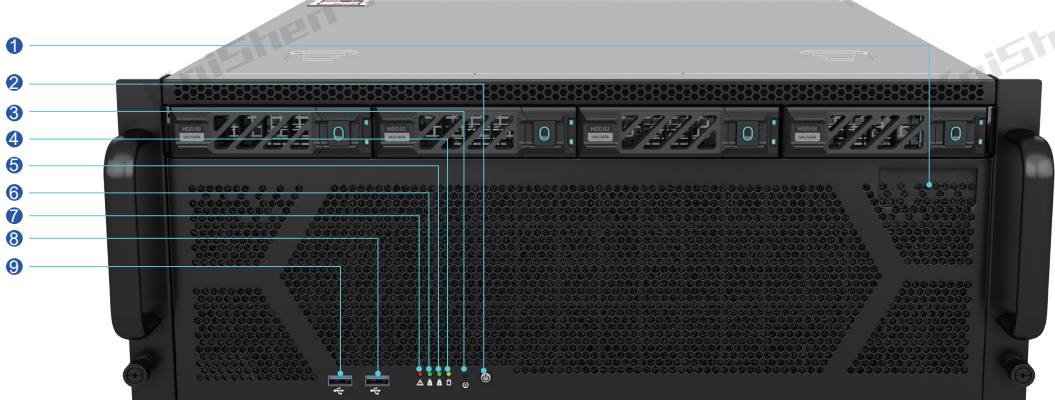

Hard Drive Installation Diagram			
HD00	HD01	HD02	HD03

- | | | |
|-----------------------------------|----------------------------------|----------------------------------|
| 1. Chassis Layout Diagram Sticker | 2. Power Button | 3. Reset Button |
| 4. HDD Indicator Light | 5. Ethernet Port Indicator Light | 6. Ethernet Port Indicator Light |
| 7. Warning Indicator Light | 8. USB Connector | 9. USB Connector |

Control Panel Buttons and Interface Description:

Power Button	Power button, press once to power on when the system is powered; In the powered-on state, press and hold for 5 seconds to shut down the system.
Reset Button	In the powered-on state, press once to restart the device.
UID Button	In the powered-on state, press once to illuminate the indicator light.

Control Panel Indicator Light Explanation:

Name	Color	Status	Description
Power Light	Blue	On	The server is in the powered-on state.
UID Light	Blue	On	The server is in the located state.
Fault Indicator Light	Red	On	The server is experiencing a malfunction.
Network 1 Indicator Light	Green	On	The network connection is normal.
Network 2 Indicator Light	Green	On	The network connection is normal.
HDD Indicator Light	Yellow	On	The hard drive is in operational status.

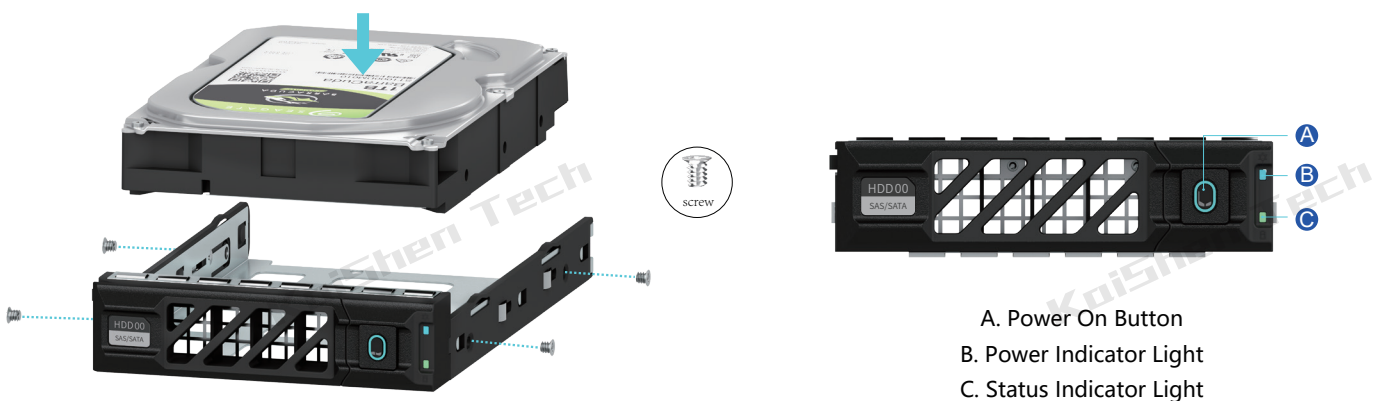
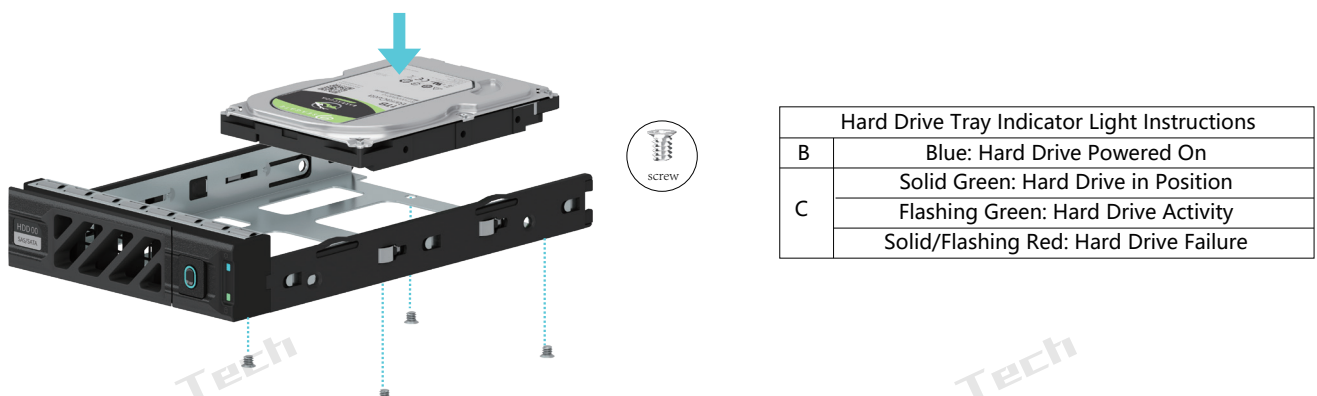
1.3.2 Hard Drive Installation and Hard Drive Tray Indicator Light Instructions:
3.5-inch Hard Drive Installation Guide:

2.5-inch Hard Drive Installation Guide:

1.4 Hard Drive Backplane

1.4.1 4-Bay Direct Attached Backplane

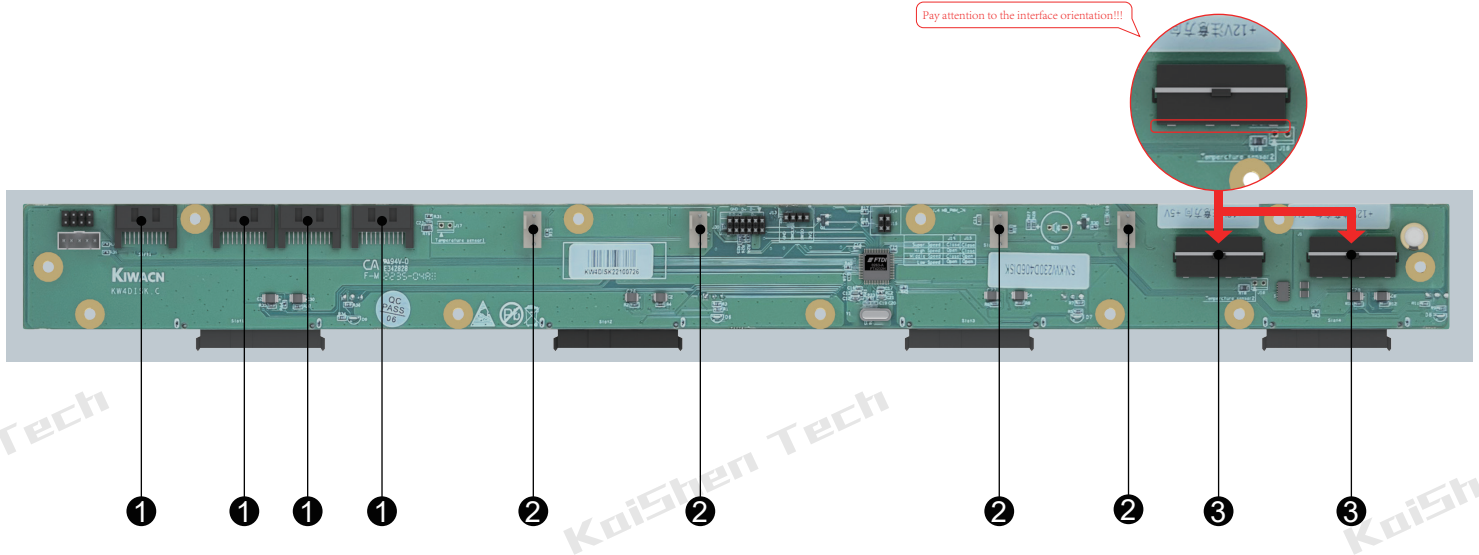
TOP Plane:



Label	Device Description	Function Description	Location Identifier
1	7 PIN SATA	Backplane Drive Slot Signal Interface	J8, J10, J12, 20
2	Fans Connector	For use with 4-pin fan connector	J3, J4, J5, J6
3	ATX 4-pin Power Connector	Backplane Power Signal Interface	J1, J2

BOTTOM Plane:

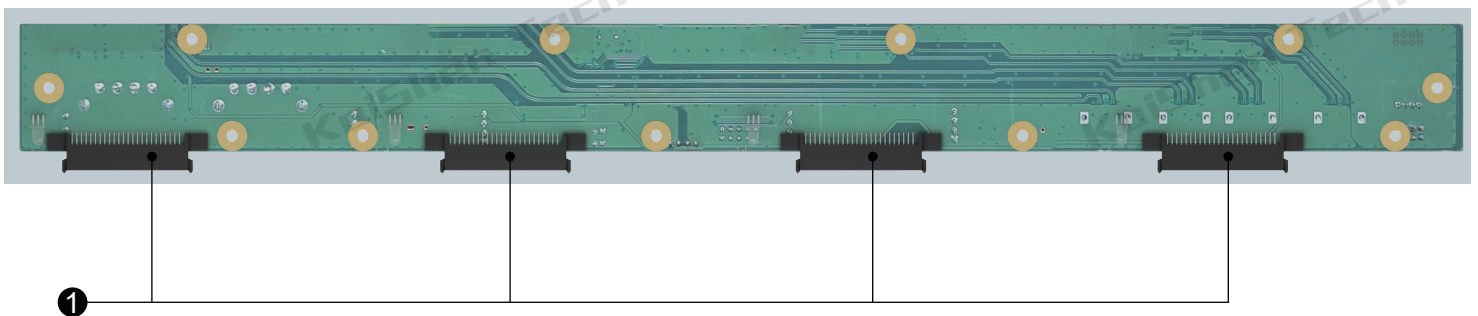

Label	Device Description	Function Description	Location Identifier
1	SAS/SATA Hard Drive Connector	1.Supports up to 6G/b SATA Hard Drives; 2.Supports Hot-Swappable SAS/SATA Hard Drives.	J7, J9, J11, J19

Chapter 2: Product Appearance

2.1 Chassis Structure

2.1.1 Chassis Diagram

Model K14007/K24006:

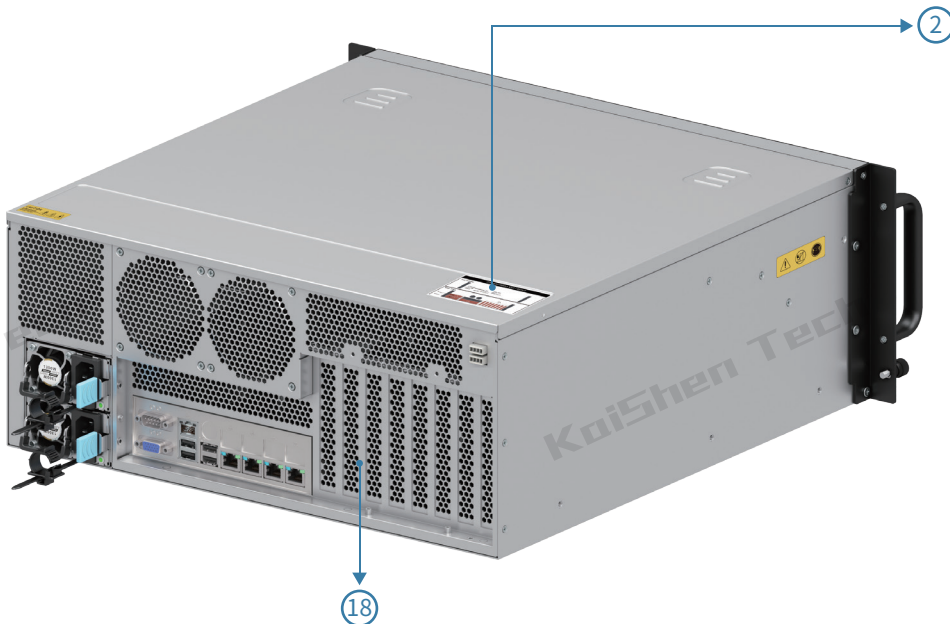

K24006 Layout Diagram Sticker:

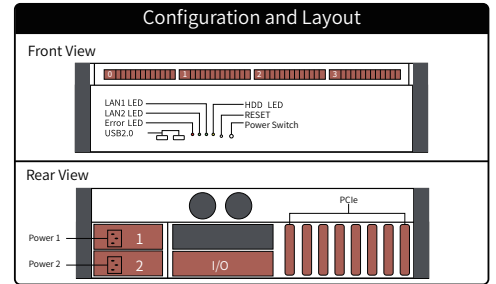

K14007 Layout Diagram Sticker:

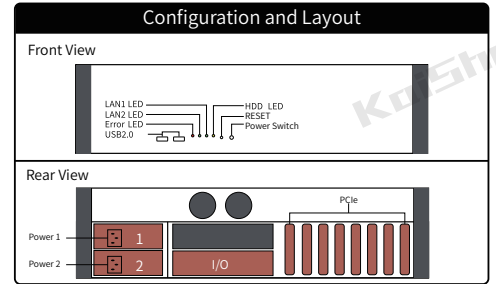

- ② Chassis Layout Diagram Sticker
- ⑱ Standard 8 PCIe Expansion Slots
- ⑲ 1+1 Redundant(Optional)

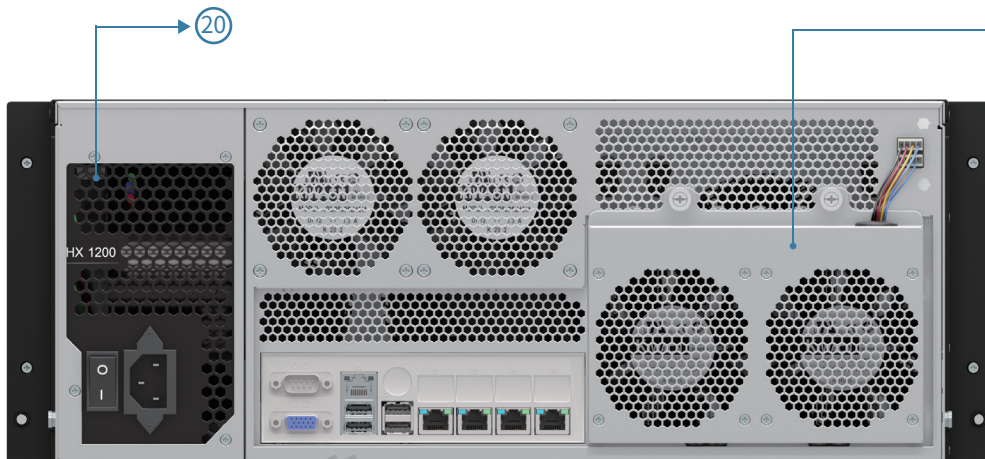

- ⑳ ATX Power(Optional)
- ㉑ Rear Fan Module(Optional)

Model K14005:

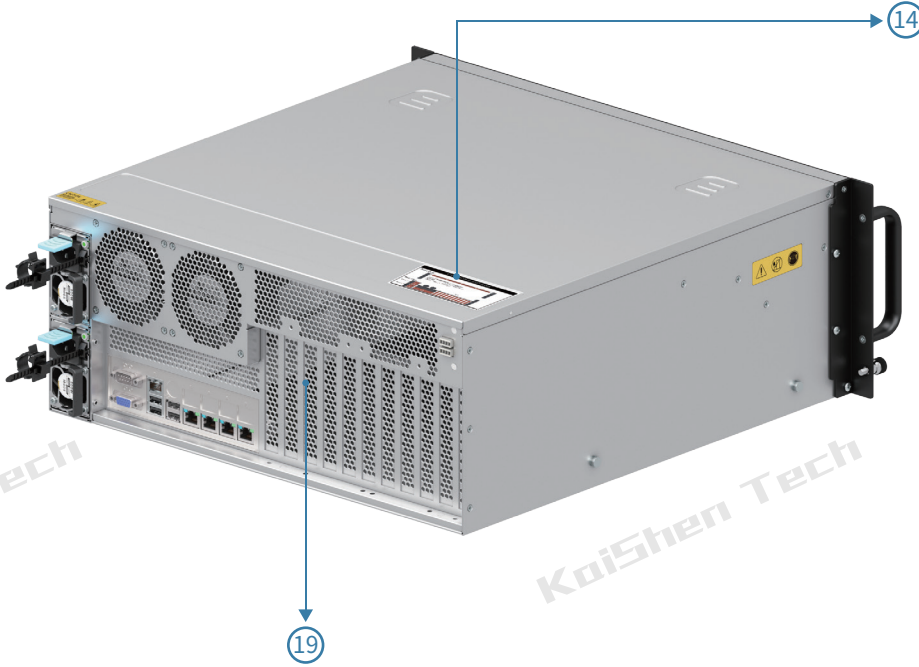

K14005 Layout Diagram Sticker:

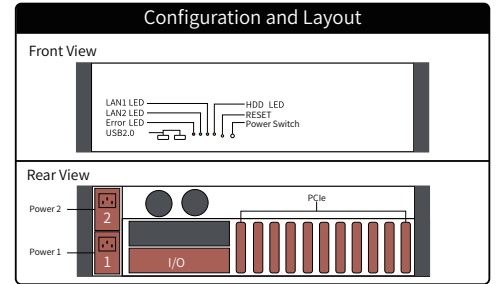

- ② Chassis Layout Diagram Sticker
- ⑱ Standard 11 PCIe Expansion Slots

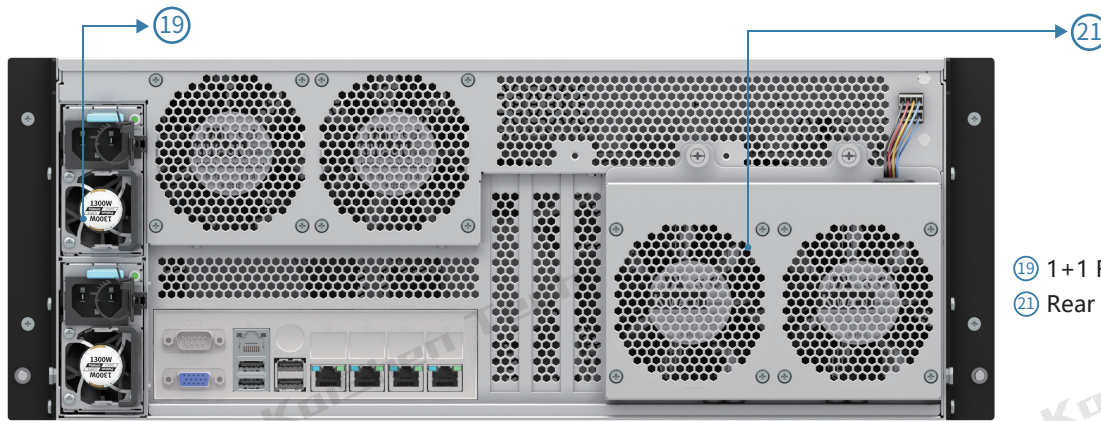

- ⑲ 1+1 Redundant(Optional)
- ⑳ Rear Fan Module(Optional)

2.1.2 Server Chassis Images

Model K14007:



Front View



45° Side View



45° Rear View

Model K34006:

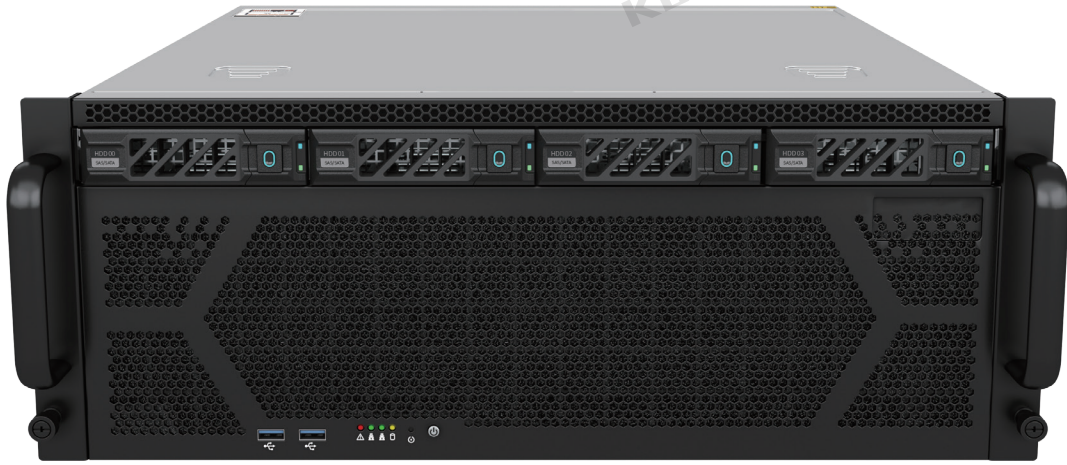

Front View



45° Side View



45° Rear View

Model K14005:



Front View



45° Side View



45° Rear View

2.1.3 Server Dimensions

Model K14007:

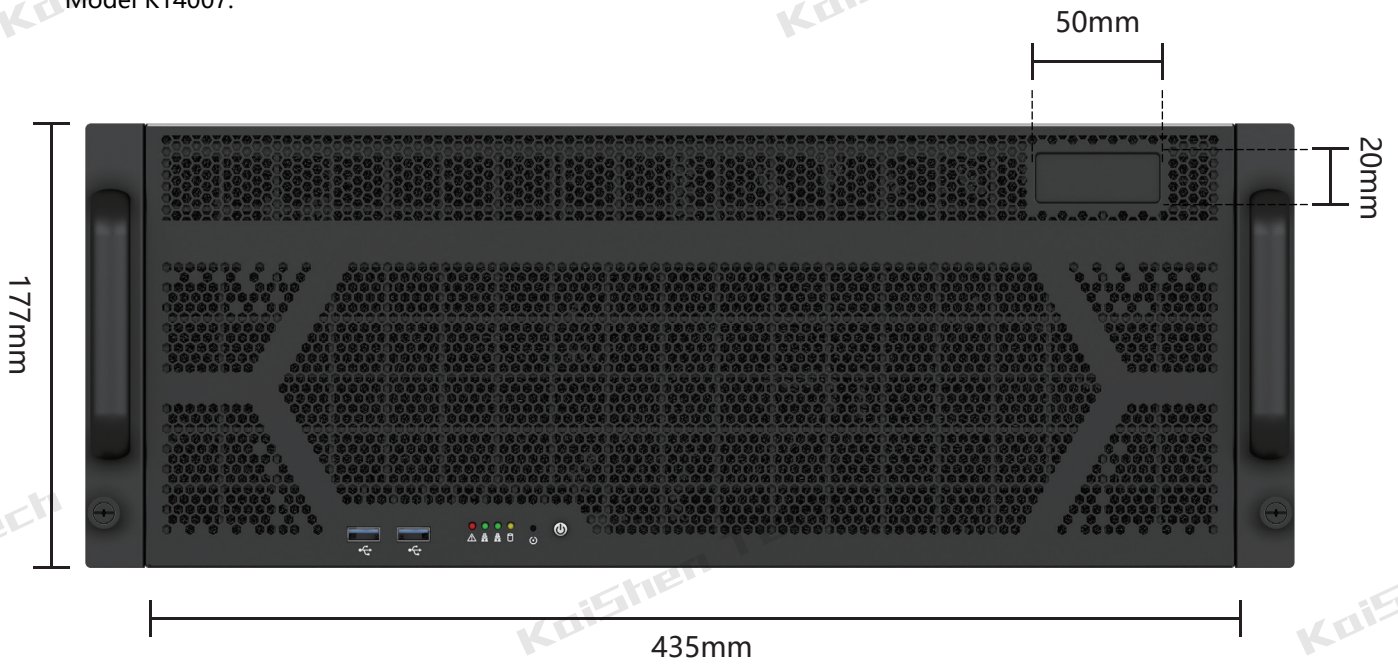

Front View (Dimensions)

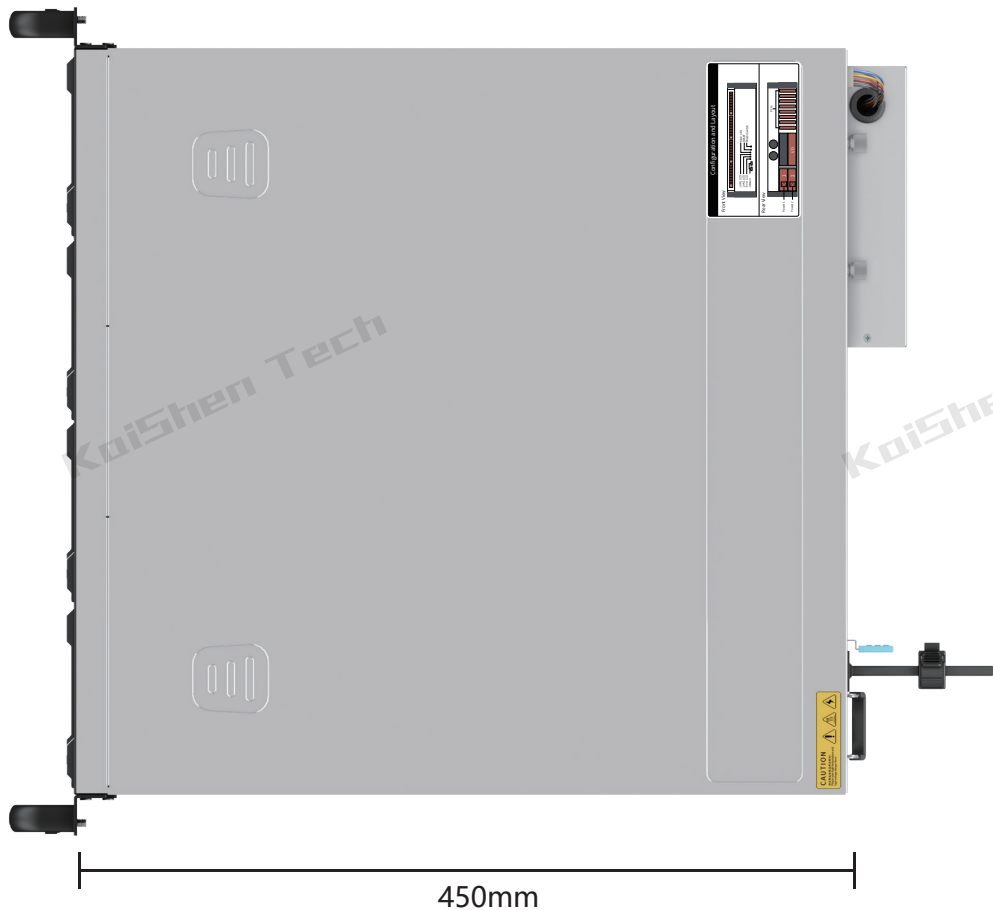

Top View (Dimensions)

Model K34006:

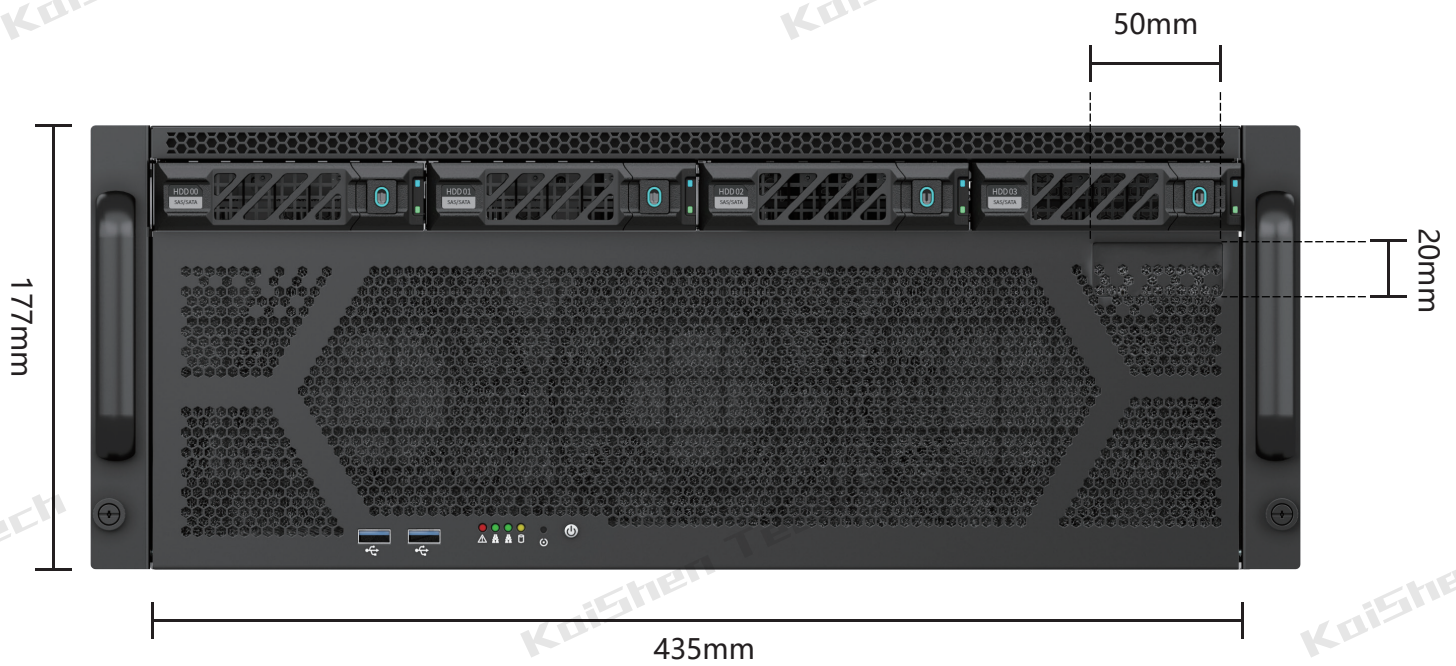

Front View (Dimensions)

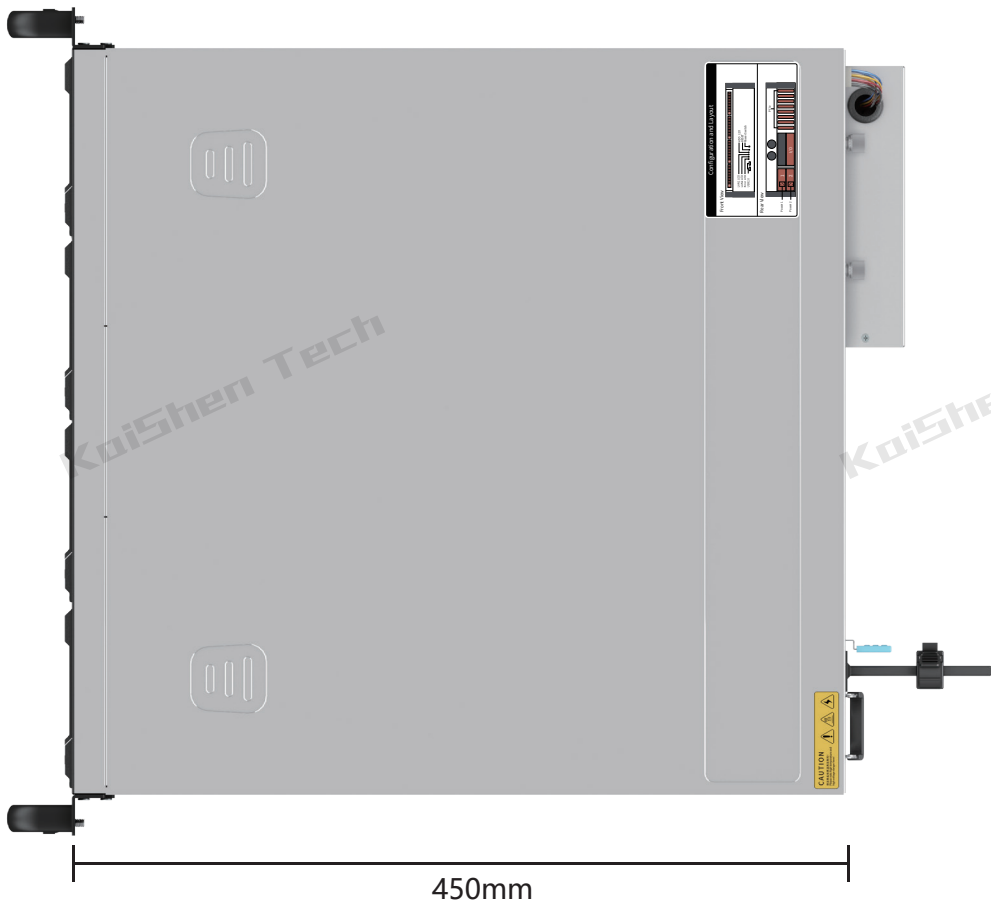

Top View (Dimensions)

Model K14005:

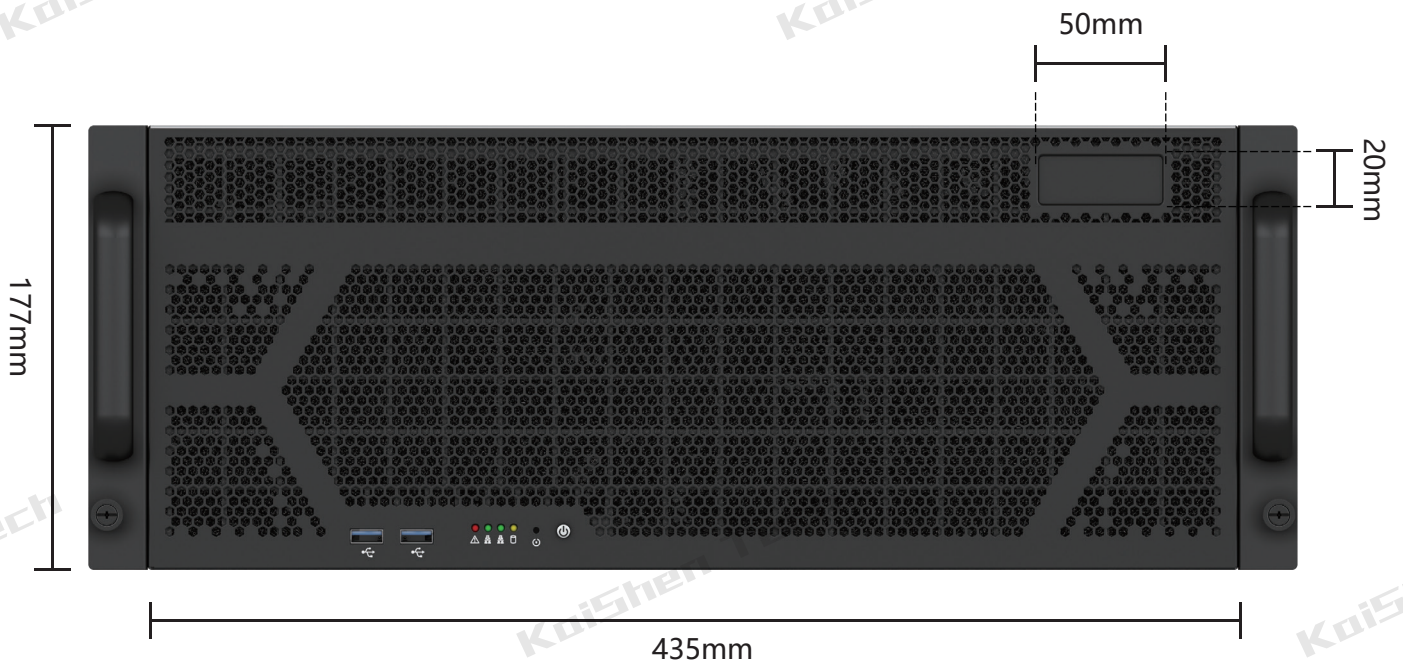

Front View (Dimensions)

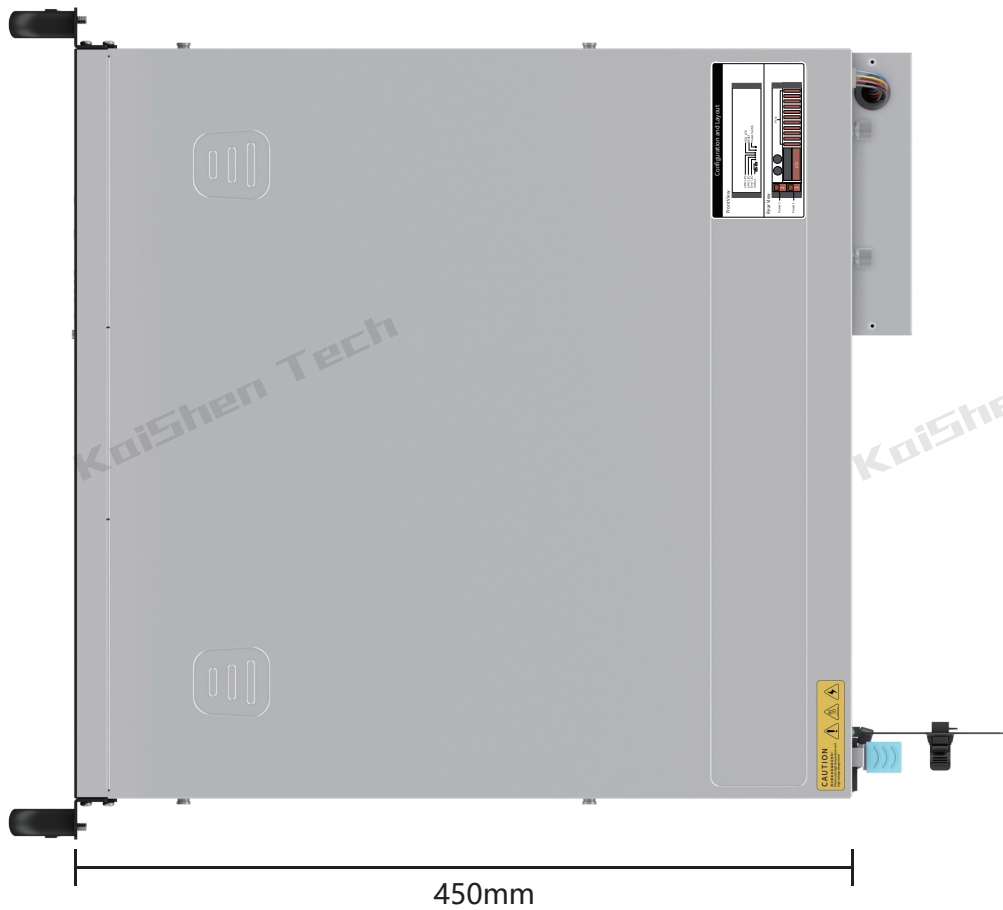

Top View (Dimensions)

Chapter 3 Product Loading and Unloading

3.1 Installation of Optical Drive

3.1.1 Steps of Installing the Optical Drive:

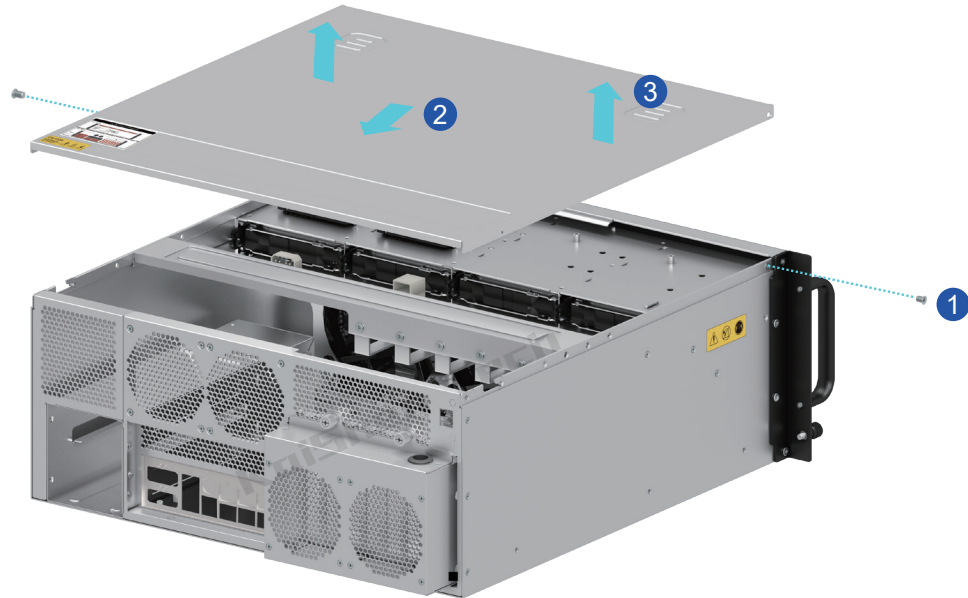

Loosen the screws on both sides in the order shown in the diagram. Then, push towards the back and lift off the top cover in the direction indicated by the arrow.

3.2 Removal of the Rear Top Cover

3.2.1 Disassembly Steps:

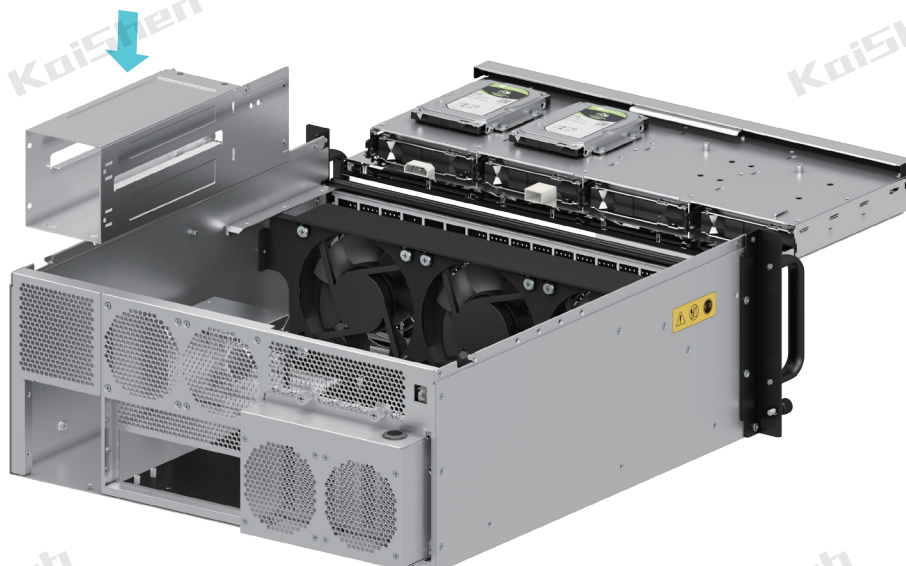

Lower the power supply bracket down, affix it to the bottom of the chassis, and push it towards the rear end. Secure three screws at the rear, and two screws from the bottom.

Note: Different power supply brackets may have slight variations in screw positions and quantity.

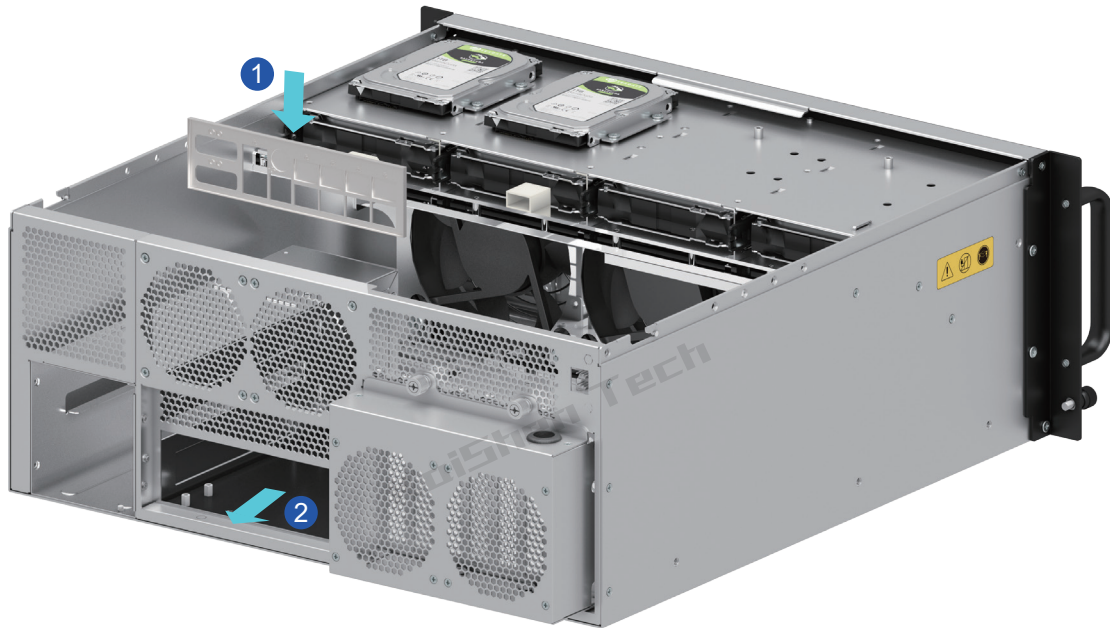

Install the I/O shield in the indicated direction, following the sequence and arrow instructions.

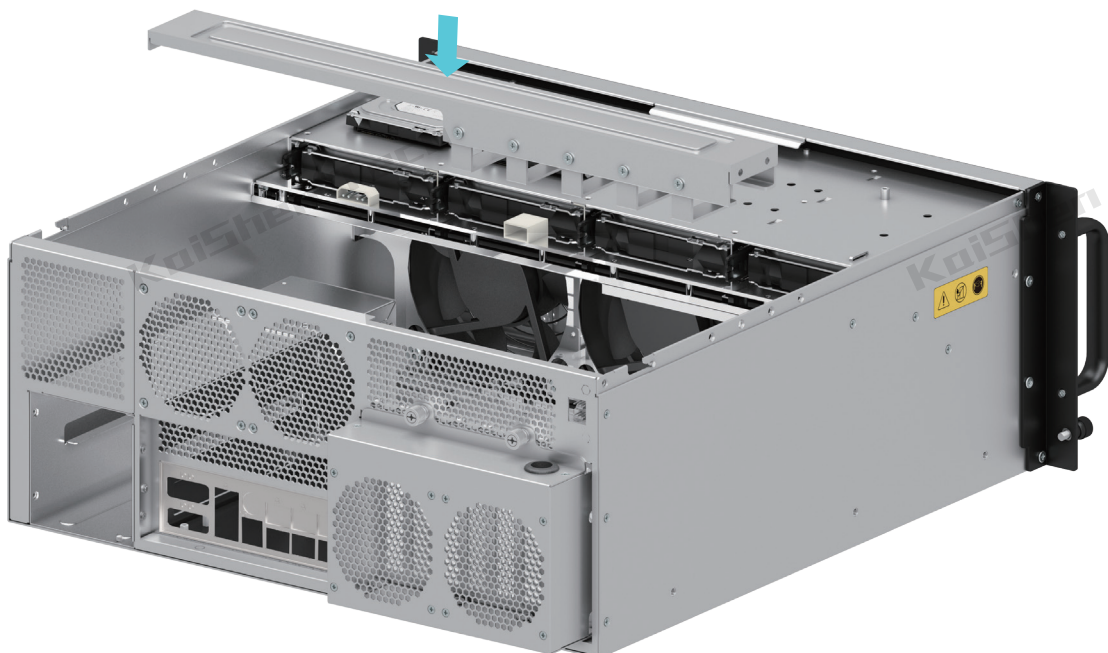

Install the graphics card bracket in the direction indicated by the arrow.

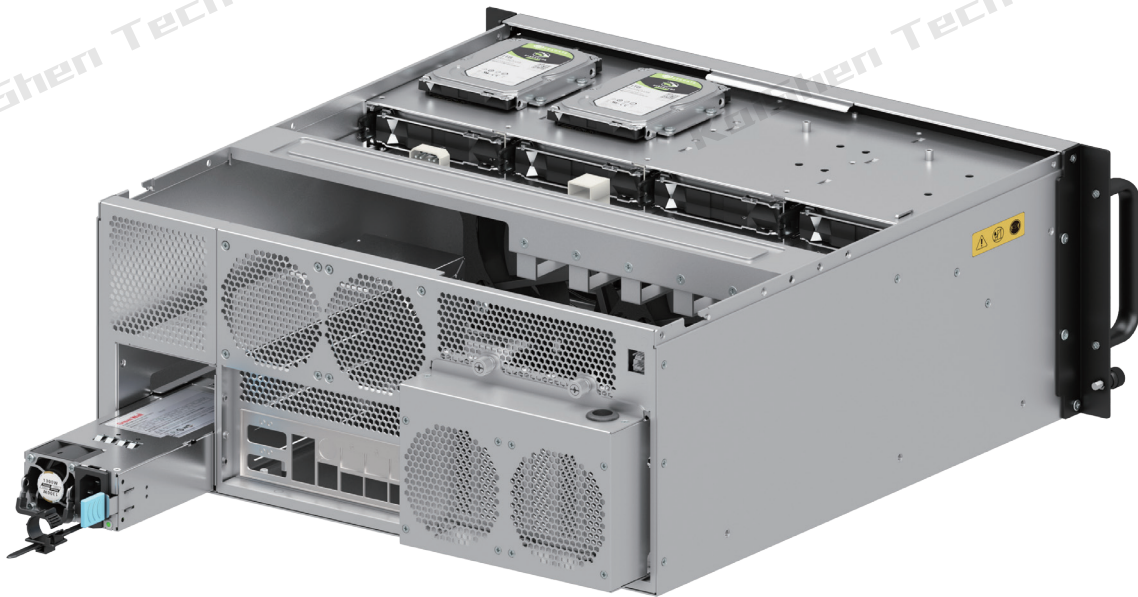

Insert power supply modules 1 and 2 into the power supply frame respectively

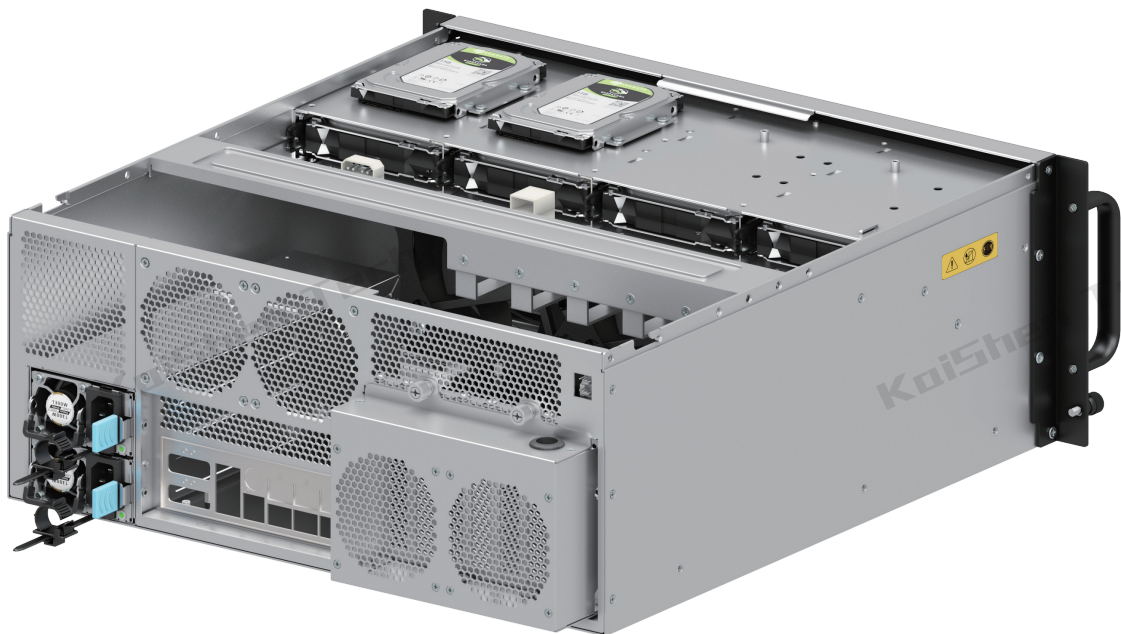

View of Installed Power Supply Unit

Chapter 4 Product Loading

4.1 Product Packaging

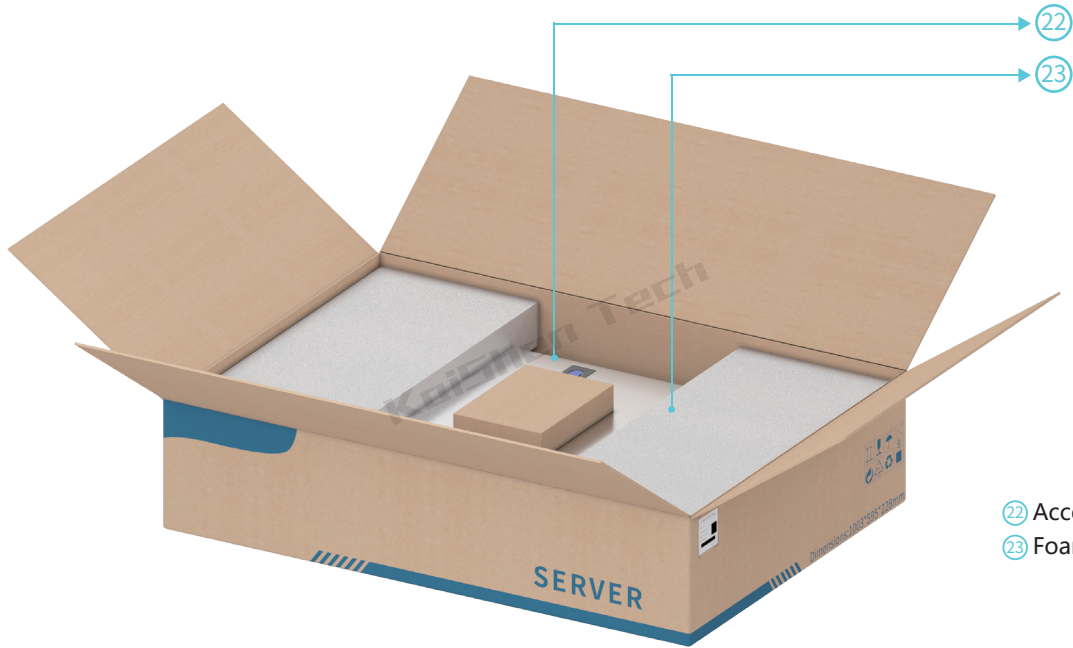

Place it into the suitcase



Seal the suitcase

Chapter 5 Product and Rail Installation

5.1 Install inner rails on both sides of the chassis (型号K14005)

- 5.1.1 Securely attach the inner rail to the side wall of the chassis, and ensure that the inner rail's latch engages with the chassis T-pin.

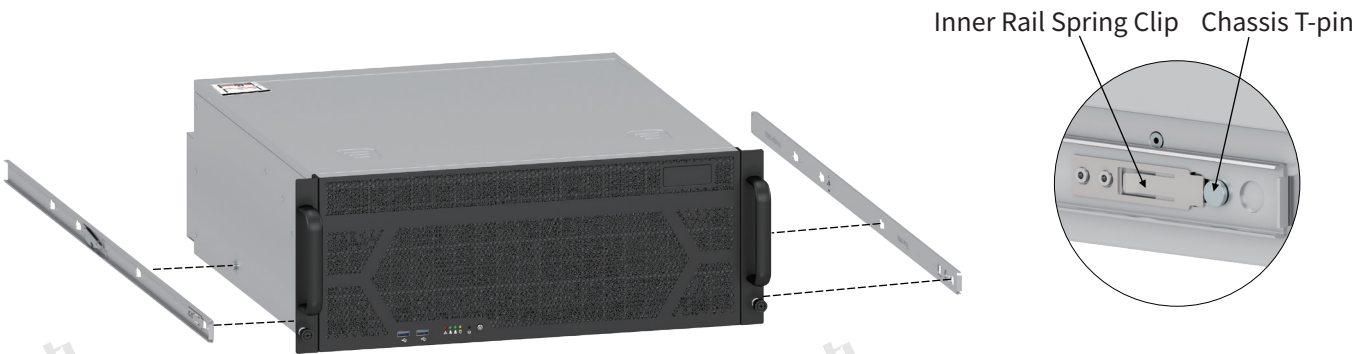

The inner rail spring clip engages with the chassis T-pin.

5.2 The chassis is mounted into the rack

(Note: Depending on the weight of the chassis, this step requires the cooperation of 2 to 4 people.)

- 5.2.1 First, move the ball seat to the front end of the middle track. Then, along the G direction, horizontally insert the inner rail of the chassis into the ball seat.
- 5.2.2 When installing the rails, ensure that both sides of the server are kept level, and insert the inner rails simultaneously in a horizontal direction.
- 5.2.3 Ensure that the inner rails have entered the guides and ball seats before proceeding to push them into the chassis.
- 5.2.4 Only release the chassis after confirming that the inner rails have entered at least half of the ball seats.
- 5.2.5 There is a limiting buckle on the inner rail. When pushing it into the second section, you need to flip this buckle to enter the third section for complete closure.
- 5.2.5 If you find that the inner rails have not entered the ball seats, please repeat the above steps. If necessary, you can use your hand to assist the inner rails into the ball seats.
- 5.2.6 Unlock both levers on the sides, then push the chassis to fully close it. Perform at least one complete open and close cycle of the chassis to ensure the slides are correctly installed.

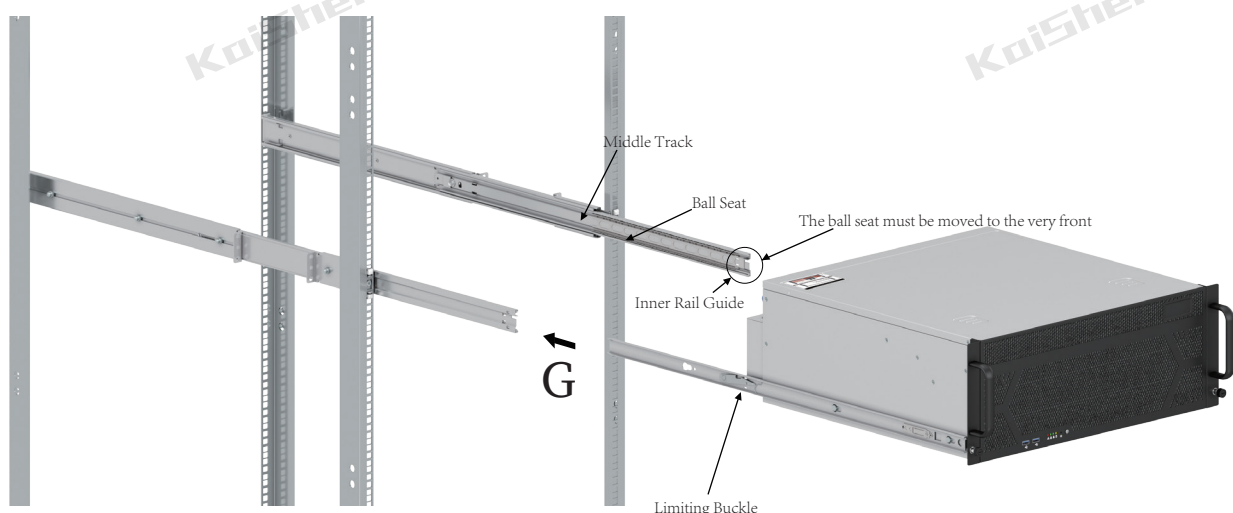

Note: Please make sure to insert horizontally in this direction. Otherwise, it may damage the ball seats and cause the slides to not function properly.

5.3 5.1 Install inner rails on both sides of the chassis (型号K24006及K14007)

5.1.1 Secure the inner rail to the side wall of the chassis by using screws in the indicated direction.



5.2 The chassis is mounted into the rack

(Note: Depending on the weight of the chassis, this step requires the cooperation of 2 to 4 people.)

- 5.2.1 First, move the ball seat to the front end of the middle track. Then, along the G direction, horizontally insert the inner rail of the chassis into the ball seat.
- 5.2.2 When installing the rails, ensure that both sides of the server are kept level, and insert the inner rails simultaneously in a horizontal direction.
- 5.2.3 Ensure that the inner rails have entered the guides and ball seats before proceeding to push them into the chassis.
- 5.2.4 Only release the chassis after confirming that the inner rails have entered at least half of the ball seats.
- 5.2.5 There is a limiting buckle on the inner rail. When pushing it into the second section, you need to flip this buckle to enter the third section for complete closure.
- 5.2.5 If you find that the inner rails have not entered the ball seats, please repeat the above steps. If necessary, you can use your hand to assist the inner rails into the ball seats.
- 5.2.6 Unlock both levers on the sides, then push the chassis to fully close it. Perform at least one complete open and close cycle of the chassis to ensure the slides are correctly installed.

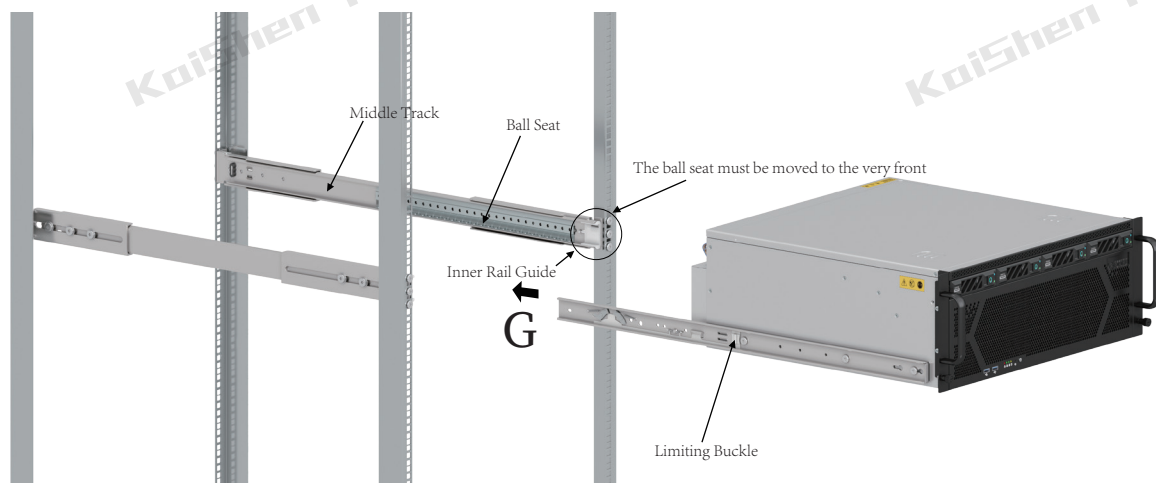

Note: Please make sure to insert horizontally in this direction. Otherwise, it may damage the ball seats and cause the slides to not function properly.

Chapter 6 Accessory Name and Part Number

6.1 Accessories and Material Numbers(Parts Box P/N:0201070009)

Applicable Type: K14007/K24006





No.	Part No.	Name	Photograph	Quantity
01	P/N: 0305010001	2.5-inch hard drive screws (Compatible with 3.5-inch hard drive bay)		56
02	P/N:0305010031	3.5inch hard drive screws		48
03	P/N:0305010124	2.5-inch Hard drive retaining screws		4
04	P/N:0305070003	Motherboard heightening column (Motherboard thickness1.6mm)		12
05	P/N:0305010203	Motherboard screws		12
06	P/N:0202110015	2.5Hard drive holder (2U8)		2
07	P/N:0305010125	Fixed single power/ATX		4
08	P/N:0305010025	Fixed redundancy		8
09	P/N:04.02.0009	hard drive sticker (00-11)		1

6.1 Accessories and Material Numbers(Parts Box P/N:0201070009)

Applicable Type: K14005

No.	Part No.	Name	Photograph	Quantity
01	P/N: 0305010001	2.5-inch hard drive screws (Compatible with 3.5-inch hard drive bay)		56
02	P/N:0305010031	3.5inch hard drive screws		48
03	P/N:0305010124	2.5-inch Hard drive retaining screws		4
04	P/N:0305070003	Motherboard heightening column (Motherboard thickness1.6mm)		15
05	P/N:0305010203	Motherboard screws		15
06	P/N:0202110015	2.5Hard drive holder (2U8)		2
07	P/N:04.02.0009	hard drive sticker (00-11)		1

6.2 Optional Accessories List

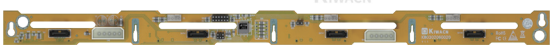
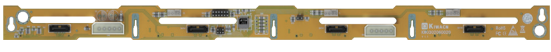
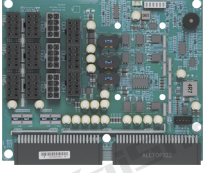
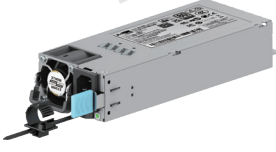
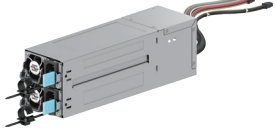
No.	Part No.	Name	Photograph
01	P/N:0304100005	slide rail	
02	P/N:0304090001	8643 Cable	
03	P/N:0304090026	NVME cable (8654 4i to 8i)	
04	P/N:0304090012	SAS (8643) cable	
05	P/N:0302060031	4bays three models (nvme/u.2/12GB backplane)	
06	P/N:0302060026	4bays 12BG backplane	
07	P/N:0302020004	3000W Power Supply Backplane	
08	P/N:0304010021	power mouldle (2700w)	
09	P/N:0304010018	1+1Redundant power mouldle (1200w)	
10	P/N:0201040016	rear cooling fans mouldle	